

MODELS

EL1000 EL1500

EL1300 EL1800

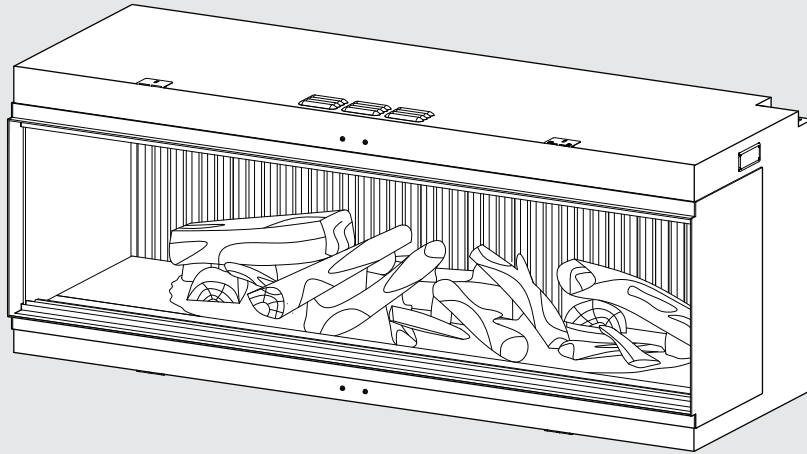

Electric Fire Heater (EL Series)
Operation & Installation Manual

Rinnai

Congratulations on the purchase of your Rinnai Electric Fire Heater. We trust you will have many years of comfort and enjoyment from your appliance.



BEFORE USING THIS APPLIANCE.

Before proceeding with the operation or installation of your new heater, please read this manual thoroughly and gain a full understanding of the requirements, features and operation of your new appliance.

This appliance must be installed in accordance with Manufacturer's Installation Instructions.

For continued safety of this appliance it must be installed and maintained in accordance with the manufacturer's instructions.

Before proceeding with the operation or installation of your new heater, please read this manual thoroughly and gain a full understanding of the requirements, features and operation.



OPERATION TABLE OF CONTENTS

Operation	7
Manual Control	7
On/Off	7
Wi-Fi On/Off	7
Standby	7
Heat Mode	7
Preset Mode	7
Remote Control	8
Button 1: Preset Mode	8
Button 2: Standby.....	9
Button 3&8: Minus & Plus	9
Button 4: Flame High/Low.....	9
Button 5: Flame Style.....	9
Button 6: Log Colour	9
Button 7: Ambient Lighting	9
Button 9: Heater Mode.....	9
Button 10: Sparks	9
Button 11: Fuel Bed Downlight.....	10
Button 12: Eco Mode	10
Button 13: Fuel Bed Colour.....	10
Button 14: Sound Effect.....	10
Wireless Setup	11
APP Installation and Setup	11
Fuel Bed Colour	12
APP Troubleshooting	12
Advanced Wi-Fi Router Guidance	13
Tips and Advice	13
Voice Control With Google Home or Amazon Alexa	13
How to Connect to Google Home or Amazon Alexa	13
Wireless Operation	14
Cleaning & Repairs	16
Cleaning	16
Repairs	16
Trouble Shooting Checklist	16
Resetting the Thermal Cut Out	16
Installation Table of Contents	17
Contacts	52

WARNINGS AND IMPORTANT INFORMATION



READ ALL INSTRUCTIONS BEFORE USING THE APPLIANCE.

Always comply with the following precautions to avoid dangerous situations and to ensure optimum performance.

Failure to carefully read and follow all instructions in this manual can result in equipment malfunction, property damage, personal injury and/or death.

DANGER: Indicates an imminently hazardous situation which, if not avoided, will result in personal injury or death.

WARNINGS: Indicates a potentially hazardous situation which, if not avoided, could result in personal injury or death.

CAUTIONS: Indicates a potentially hazardous situation which, if not avoided, could result in minor or moderate injury or damage to the appliance. It may also be used to alert against unsafe practices.



REGULATORY / Installation

This appliance must be installed in accordance with Manufacturer's Installation Instructions.

The appliance is intended only for domestic heating applications, and not intended for non-domestic and commercial applications. It is important that the following precautions are followed to minimise the risk of overheating, fire, electric shock and injury.

Handle the appliance with care, avoid vibrations and knocks. Unpack the appliance and check for damage. DO NOT INSTALL A DAMAGED Appliance. If the appliance is damaged or defective, contact your supplier for advice, the appliance may only be serviced by the manufacturer or the manufacturer's agent or similarly qualified person.

DO NOT install or use the appliance if the power cord is damaged. If it is damaged or requires replacing, it MUST be replaced by the manufacturer or the manufacturer's agent or similarly qualified person.

The heater is fitted with an Australian flexible cord and 3 pin plug intended for connection to an Australian 240 V, 50 Hz, 10 Amp, earthed socket outlet supplied from mains electricity. It is not suitable for connection in other countries or alternative power supplies. Ensure that the voltage and frequency of the power supply correspond to the ratings on the dataplate of the appliance.

DO NOT use power boards, double adaptors or extension leads for this appliance.

The 3 pin plug must remain accessible after the appliance is installed. The heater must not be located below an electric socket outlet. The connection of the appliance to a permanent electrical supply (hard-wiring) and the installation of any other electrical wiring, power outlets and switches must be performed by a person authorised under the legislation of your local electrical authority, such as a licensed electrician.

Do not connect the appliance to the mains power until it has been installed in its final location and adjusted to the position it will be used in.

DO NOT handle any parts of the heater, including the plug and flexible cord, with wet or damp hands.

DO NOT immerse the appliance, flexible cord and plug in water or any other liquid.

DO NOT place containers of any liquid or wax on the heater.

This appliance is suitable for indoor use only.

Never dismantle the appliance. Tampering with electrical connections and components is highly dangerous and may cause appliance malfunction. Repairs to be performed only by a qualified person such as an electrician.

The flexible cord and plug MUST NOT be modified. If the power cord or its plug is damaged, it MUST be replaced with a new certified cord and plug installed by a suitably qualified and licensed person.



WARNING! DO NOT COVER. In order to avoid overheating, **DO NOT cover the heater or air vents located on the appliance or obstruct the air circulation around the appliance.**

This appliance must not be installed where curtains or other combustible materials could come into contact or in close proximity with it. In some cases curtains may need restraining.

DO NOT place articles or on or against this appliance any parts of this heater, to avoid overheating.

DO NOT sit on this heater.

Do not place any items of clothing, hand towels or similar over the appliance to dry.

DO NOT spray aerosols in the vicinity of this appliance whilst the appliance is operating. Most aerosols contain flammable gas, which can be a fire hazard if used near the appliance when it is in use.

DO NOT use or store flammable materials, liquids, etc. near this appliance. Combustible materials MUST not be placed where the appliance could ignite them.

Do not use the appliance in areas where the presence of flammable dust particulates may cause an explosion.

This appliance is intended only for domestic heating applications. It is not intended for non-domestic or commercial applications.

Do not use the appliance as a sauna heater.

DO NOT leave the appliance unattended whilst in operation.

Caution when being operated the surfaces of this appliance will get VERY HOT - do not touch any part of the appliance while it is turned on. To avoid burns, DO NOT touch the any surface of the appliance with any body part.

The appliance will retain significant heat for a period after shut down. To avoid burns, do not touch the any surface of the appliance with any body part during this period.

This appliance is not intended for use by persons (including children) with reduced physical, sensory or mental capabilities or lack of experience and knowledge, unless they have been given supervision or instruction concerning use of the appliance by a person responsible for their safety and have the capacity to follow those instructions.

The appliance is not intended for use by young children or infirm persons without supervision.

Young children should be supervised when in the vicinity of this appliance while it is in operation to ensure they DO NOT play with the appliance.

DO NOT allow children or persons with reduced physical, sensory or mental capabilities to sleep directly in front of the heater.

DO NOT allow children to 'post articles' into the louvres of the heater.

No USER SERVICEABLE PARTS - Never dismantle the appliance. Tampering with electrical connections and components is highly dangerous and can result in equipment malfunction, property damage, personal injury and/or death. Repairs to be performed only by a qualified person such as an electrician.

DO NOT modify this appliance. Modifying from original specifications may create a dangerous situation and will void your warranty.

DO NOT use this heater if it has been dropped.

DO NOT use if there are visible signs of damage to the heater.

DO NOT use this heater in small rooms when they are occupied by persons not capable of leaving the room on their own, unless constant supervision is provided.

To reduce the risk of fire, keep textiles, curtains, or any other flammable material a minimum distance of 1 m from the air outlet.



NOTE TO INSTALLERS AND CONSUMERS

A dedicated, properly fused circuit is required, rated for the appropriate voltage (230-240V). An isolation switch should also be incorporated in cases where the product plug is inaccessible after installation.

This appliance must be earthed.

Please leave this operation and installation manual, suction cups and magnetic tools in a handy place for future use.



MANDATORY INSPECTION PRIOR TO INSTALLATION

Immediately report any damage or discrepancies to your appliance supplier. This appliance has been inspected and tested at the time of manufacture and packaging, and was released for transportation without known damage. Upon receipt, inspect the exterior for evidence of rough handling in shipment. Ensure that the appliance is labelled correctly for the electrical supply it is intended to be connected to.

For safety and warranty purposes, appliances that may be damaged or incorrect MUST NOT be installed or operated under any circumstances. No responsibility will be accepted for installation or operation of damaged or incorrect appliances. Installation of damaged or incorrect appliances may also contravene local regulations.



A NOTE ON ILLUSTRATIONS

The illustrations used in this manual are for explanatory purposes only and the shape of your unit may vary slightly from that which is shown in this manual.

DISPOSAL GUIDELINES

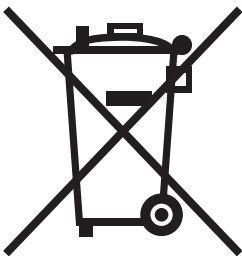

This appliance contains potentially hazardous materials. Do not dispose of this product as household waste or unsorted municipal waste. Local regulations may require special collection and treatment, confirm with your local municipal council which disposal options apply in your area.



Special notice – Disposing of this appliance in the forest or other natural surroundings and may endanger your health and is bad for the environment. Hazardous substances may leak into the ground water and enter the food chain.



When the appliance is turned on for the first time, the fuel bed will flash orange for a short time. This indicates that the appliance is warming up. The flashing will cease after approximately 10 seconds and the flame effect will activate.

The appliance can be operated conveniently in 4 different ways: manually using controls on the appliance, via the remote control handset, via the dedicated iOS/Android app, or with voice commands using Amazon Alexa or Google Assistant smart device.

MANUAL CONTROL

The manual control buttons can be located to the right side of the heater outlet. Refer to Figure 1 below.

Figure 1.

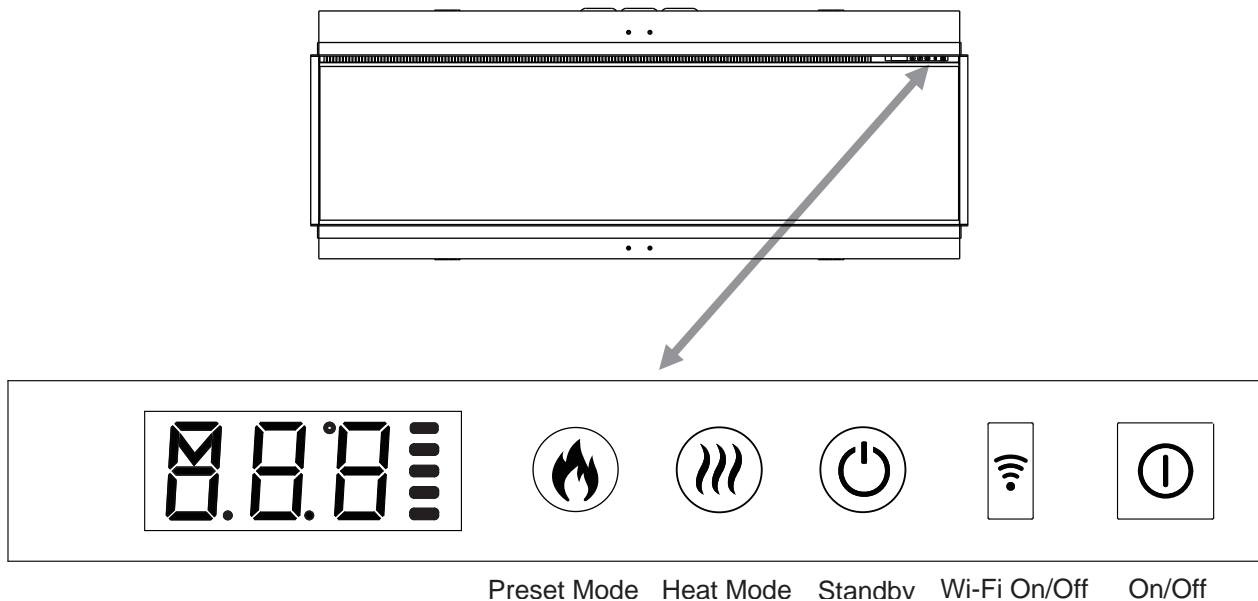

Each time a button is pressed on the appliance, remote control or app, an audible beep is emitted. To turn off this feature hold your finger on the Preset Mode button (on the appliance) for 3 Seconds.

On/Off

Press to turn on power to the appliance. Button pushed in indicates power is on, button pushed out indicates power is off.

Wi-Fi On/Off

Press to turn Wi-Fi on or off. An illuminated LED on the button indicates that Wi-Fi is turned on. Hold button for 3 seconds to enter device pairing mode.

Standby

Turns on the appliance with the last used settings without any heat. Places the appliance into standby mode with all features turned off.

Heat Mode

1 press = cool blow. 2 press = low heat setting. 3 press = high heat setting. 4 press = no heat/no cool blow.

Preset Mode

Press repeatedly to cycle through the 6 fire preset modes (+3 user defined pre-sets if programmed).

REMOTE CONTROL



KEEP BATTERIES OUT OF REACH OF CHILDREN.

DO NOT:

Mix old and new batteries.

Use different types of batteries at the same time.

Heat or expose to flame.

Take apart or short circuit.

Attempt to recharge alkaline batteries.

Use batteries if their covering has been damaged or peeled off.

Dispose of used batteries safely.

Remove batteries if controller is not used for long periods to help avoid damage from leaking batteries.

Ensure that 2 x AAA batteries are inserted into the remote control handset. The battery power level is indicated by the column of bars to the right side of the temperature display when the appliance is in standby mode. 5 bars indicates the batteries are full, 1 bar indicates the batteries are empty and need to be replaced immediately.

Figure 2. Remote Control Functions

Button 1: Preset Mode 

Repeatedly press to cycle through the 6 preset fire modes (+ 3 user defined presets if programmed).

- On screen Pr.1 = Log Burner**
- On screen Pr.2 = Modern Loft**
- On screen Pr.3 = Lazy Glow**
- On screen Pr.4 = Neon Romance**
- On screen Pr.5 = Campfire Sparks**
- On screen Pr.6 = Glowing Ember**
- On screen Pr.7 = User Preset**
- On screen Pr.8 = User Preset**
- On screen Pr.9 = User Preset**



The remote control handset must be left in the same room as the appliance as it houses the thermostat that regulates heat output.

There are 3 preset spaces allocated for the user to save personalised Electric Fire creations. Simply choose the flame colour and brightness level, the fuel bed colour and brightness level and fuel bed downlight colour and brightness level. Once you have selected your desired combination, press and hold the Preset Mode button for 3 seconds until the LCD displays Pr.7. Press – and + buttons to select a slot number between 7-9. Press and hold the Preset Mode button for 3 seconds to confirm the preset.

Button 2: Standby 

Turns on the appliance with the last used settings without any heat. Places the appliance into standby mode with all features turned off.

Button 3&8: Minus (–) & Plus (+)

Use to navigate through different on-screen menus.

Button 4: Flame High/Low 

Press to select high flames or low flames.

On screen F.Lo = Low flames

On screen F.HI = High flames

Button 5: Flame Style 

Repeatedly press to cycle through flame style menu.

On screen FL.0 = Flame off

On screen FL.1 = Flame type A (gas style flame), Orange

On screen FL.2 = Flame type A (gas style flame), Yellow

On screen FL.3 = Flame type A (gas style flame), White

On screen FL.4 = Flame type B (wood burning style flame), Orange

Button 6: Log Colour

Repeatedly press to cycle through log colour menu. While in the log colour menu, press the plus and minus buttons to increase and decrease the fuel bed brightness - 1 bar is the dimmest setting, 5 bars is the brightest setting.

On screen Lc.0 = Fuel bed off

On screen Lc.1 = Red

On screen Lc.2 = Orange

On screen Lc.3 = Yellow

On screen Lc.4 = Green

On screen Lc.5 = Light Blue

On screen Lc.6 = Dark Blue

On screen Lc.7 = Violet

On screen Lc.8 = White

On screen Lc.9 = Multi-colour auto change

Button 7: Ambient Lighting (*if appliance is fitted with optional Ambient Lighting Kit*) 

Repeatedly press to turn on ambient lighting and cycle through the different colour options.

Button 9: Heater Mode 

Press to cycle through the heat output options.

1 press: Co.A = Cool blow setting

2 press: H.Lo = Low heat setting

3 press: H.HI = High heat setting

4 press: no.H = No Heat (heat off / standby)

Button 10: Sparks 

Press to activate or deactivate the sparks and smoke feature.

On screen SP.0 = Sparks off

On screen SP.1 = Sparks on

Button 11: Fuel Bed Downlight

Repeatedly press to cycle fuel bed downlight colour menu. From the fuel bed down light colour menu, press plus and minus buttons to increase or decrease fuel bed brightness - 1 bar is the dimmest setting, 5 bars is the brightest setting.

On screen dL.0 = Light off

On screen dL.1 = Warm white

On screen dL.2 = Cool white

Button 12: Eco Mode

Press to activate Eco mode. This mode will reduce the brightness of all lighting modes and limit the heat output to low setting, resulting in reduced energy consumption. Press the button a second time to exit Eco mode.

Button 13: Fuel Bed Colour

Repeatedly press to cycle fuel bed colour menu. From the fuel bed colour menu, press plus and minus buttons to increase or decrease the fuel bed brightness - 1 bar is the dimmest setting, 5 bars is the brightest setting.

On screen Fb.0 = Fuel Bed off

On screen Fb.1 = Red

On screen Fb.2 = Orange

On screen Fb.3 = Yellow

On screen Fb.4 = Green

On screen Fb.5 = Light Blue

On screen Fb.6 = Dark Blue

On screen Fb.7 = Violet

On screen Fb.8 = White

On screen Fb.9 = Multi-colour auto change

Button 14: Sound Effect

Press to open the sound effect menu.

1 press: S.on = Sound effect on

2 press: no.S = Sound effect off

While in the sound effect menu, press the plus and minus buttons to increase and decrease the volume - 1 bar is the quietest setting, 5 bars is the loudest setting.

APP INSTALLATION AND SETUP

To connect your appliance to the App, you will need the following:

- A device running Android or iOS such as a tablet or smart phone
- Network within range of the fire
- Valid email address, which you can access for verification

Visit your device app store (iOS or Android) to download the TUYA SMART APP. Once installed, launch the app and follow the directions to create an account. A valid email address will be required to complete the account set up process. Once your account is set up you will receive a number of permission requests. Please follow the on-screen prompts

Step 1.

Download the Tuya Smart app from your app store and once installed, open the on your device.

Sign up for a Tuya account or log in using an existing account.

Add device manually.

Press "Add Device". Select "Small Home Appliance" then select "Heater Wi-Fi".

Ensure the appliance is powered on, then press and hold the button on the appliance until you hear 3 beeps. At the same time the button will flash and the fuel bed will flash.

Follow the instructions on the App to input your home network details. Note, your device must also be connected to the same home network you wish to connect the appliance.

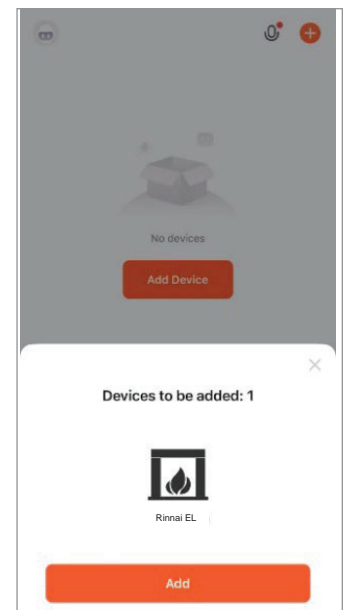
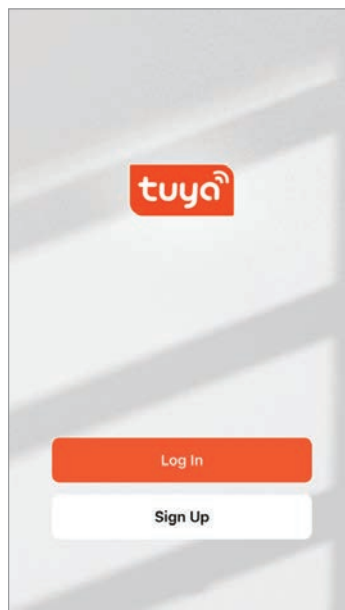

Step 2.

Tuya may automatically notify you there is an appliance ready to connect. If not, press the Add Device button in the middle of the screen to search for the appliance.

When the appliance is discovered, press the fireplace icon to connect.

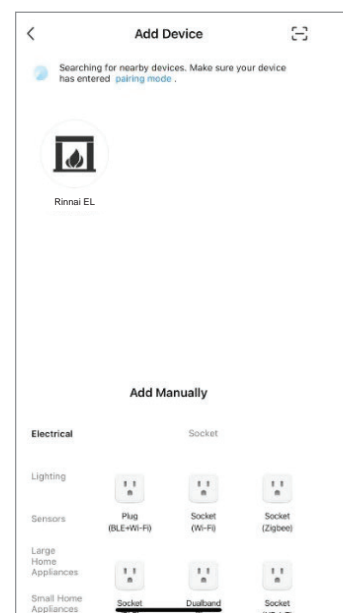
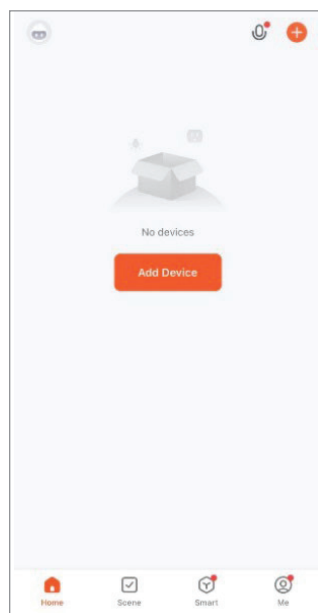

Step 3.

Select or enter your Wi-Fi network name and password.



Your device must be connected to the same network.

Once connected the appliance will be listed as 'Rinnai EL'. You may rename the appliance by pressing the pencil icon.

When ready, press the appliance button to be taken to the home screen. Turn on your appliance using the app by pressing the power button in the bottom left corner of the screen.

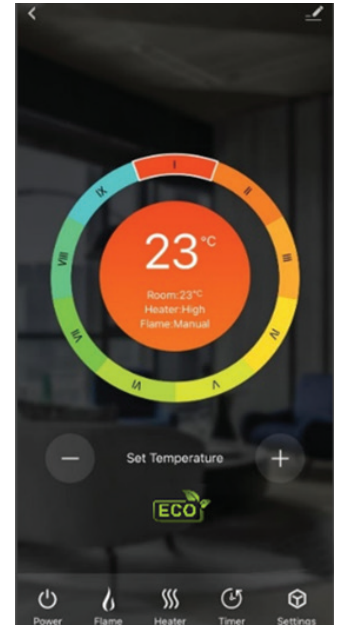
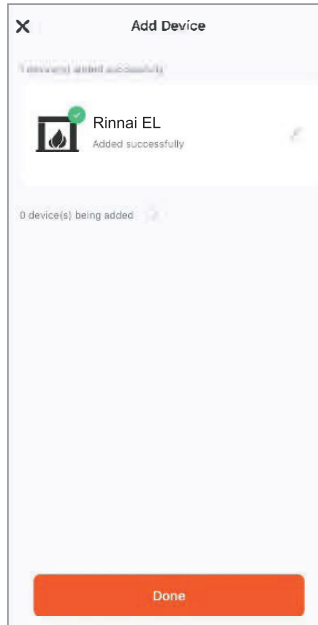

If the appliance still fails to turn on after four attempts, contact Rinnai as a service call may be required.

FUEL BED COLOUR



The fuel bed colour indicates the status of the fire. When first initiating the pairing the fuel bed will flash red. Once successfully paired the fuel bed will display green. If a flashing blue fuel bed appears check your connection and repeat the pairing procedure.



Flashing Red – In Pairing



Flashing Green – Successfully Paired

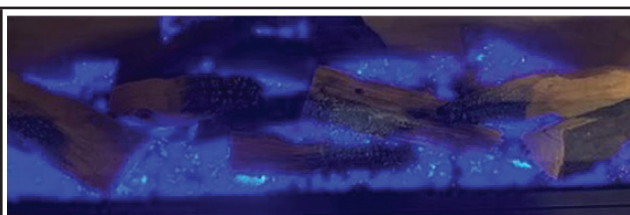

Flashing Blue – Failed Pairing

APP TROUBLESHOOTING

If configuration continues to fail, please check:

- Ensure your appliance is in standby mode.
- Your appliance and smart phone is in Wi-Fi router coverage.
- Your smartphone/tablet is connected to your home network.
- Ensure the latest version of the App is installed on your phone or tablet.
- Check your network has a good signal strength.

If you are still experiencing issues, uninstall the app from your device and reinstall then repeat the above steps.

ADVANCED WI-FI ROUTER GUIDANCE

In order to connect your appliance, make sure you choose 2.4G frequency range, bandwidth setting 802.11b/g mode.

The range of wireless transmissions can reduce at high frequencies, because at those levels they do encounter difficulties when trying to penetrate through solid objects, these objects can be structural, or general building fabrics, such as metal framework, walls & floors.

For the best possible connection to your appliance, the location of your Wi-Fi router in relation to your appliance is key:

- If there are certain areas of your home where you find your signal drops, it may be due to a blockage.
- Large objects can often obstruct or interfere with a wireless connection, so it's best to keep your router off the ground and away from larger items.
- Avoid putting your router behind the sofa, inside a cabinet or behind a door. Although it may look tidy, if you are experiencing an issue this could be the cause a problem. You should also keep electronics such as microwaves, lamps, speakers, TVs and monitors as far away from the router as possible.

If issues are encountered when trying to connect your appliance, our best advice would be to follow the below:

- Check the location of the appliance in relation to the wireless router, are there any objects that may be causing a blockage problem with the signal?
- Check if you are experiencing the same connection problem across other devices, you can do this by checking their Wi-Fi status. Typical devices to be checked would be your mobile phone, tablet, laptop, or even your TV.
- Try adding a new device to your wireless network – this will verify that the wireless password & SSID are correct.
- Are you using wireless extenders? If so, turn off all wireless extenders and add try adding a new device (a mobile phone for example) in the same location as your wireless router. This confirms that your Wireless router is accepting new devices without issue.
- The last step would be to reset the wireless router.

TIPS AND ADVICE

If the appliance is installed out of the range of your wireless network, the Wi-Fi signal will not be detected by the appliance. It may be too far away from your router. You may need to purchase a signal booster to extend the range of your home network. You can purchase a Wi Fi booster from any computer store, online or an electrical retailer.

How do I know if my Wi-Fi signal is strong enough or if the appliance is out of range?

Simply stand in front of the appliance holding a smart device (such as a phone or tablet) that is already connected to your home router, in close proximity to the control panel – you will find the control panel on the front of the appliance to the right side of the heater outlet. Check the Wi-Fi indicator on the smart device to determine the signal strength. If the signal strength is not full, it may indicate a connectivity issue. If they are greyed out or only 1 or 2 bars are showing, then the signal strength of your home network may need boosting in order for your Tuya App to control the appliance.

If the connection problems persist and you are unable to connect to the appliance, please contact your network provider for advice on the best solution.

VOICE CONTROL WITH GOOGLE HOME OR AMAZON ALEXA

An Amazon Alexa or Google Assistant smart device is required to utilise the voice control system. After setting up your Rinnai appliance with the Tuya app, connect it to your chosen smart device. Instructions on how to install are illustrated below.

HOW TO CONNECT TO GOOGLE HOME OR AMAZON ALEXA

In the Tuya app, select your appliance which will then show the circular temperature dial. Tap the Settings icon (depicted by a pen and lines) in the top right hand corner of the screen. Next, tap 'Third-party Control' and choose either Alexa or Google Assistant. Finally, click either 'Link to Amazon Alexa' or 'Link to Google Assistant' and follow the on-screen instructions to complete the pairing setup.

WIRELESS OPERATION

Once paired, the following voice commands can be used. Refer to table below.



<Rinnai EL> refers to the name set for the Rinnai appliance within the smart device settings. This can be changed to suit your preference.

Google Device	
Function	Command
Fireplace On/Off	OK Google, turn on <Rinnai EL>
	OK Google, turn off <Rinnai EL>
Flame On/Off	OK Google, turn on flame on <Rinnai EL>
	OK Google, turn off flame on <Rinnai EL>
Flame Mode (Auto/Manual)	OK Google, set flame mode on <Rinnai EL> to auto
	OK Google, set flame mode on <Rinnai EL> to manual
Heater On/Off	OK Google, turn on heater on <Rinnai EL>
	OK Google, turn off heater on <Rinnai EL>
Heater Auto/Low/High	OK Google, set heat mode on <Rinnai EL> to auto
	OK Google, set heat mode on <Rinnai EL> to low
	OK Google, set heat mode on <Rinnai EL> to high
My Flame Preset	OK Google, set my favourite flame on <Rinnai EL> to 1 (or 2 - 9)
Flame Colour	OK Google, set flame colour on <Rinnai EL> to 1 (or 2, 3, 4)
	OK Google, set flame colour on <Rinnai EL> to off
Flame Height	OK Google, set flame height on <Rinnai EL> to low
	OK Google, set flame height on <Rinnai EL> to high
Sparks On/Off	OK Google, turn on sparks on <Rinnai EL>
	OK Google, turn off sparks on <Rinnai EL>
Fuel Bed Colour	OK Google, set fuel bed colour on <Rinnai EL> to 1 (or 2 - 9)
	OK Google, set fuel bed colour on <Rinnai EL> to off
Glowing Logs Colour	OK Google, set glowing logs colour on <Rinnai EL> to 1 (or 2 - 9)
	OK Google, set glowing logs colour on <Rinnai EL> to off
Down Light Colour	OK Google, set down light colour on <Rinnai EL> to orange
	OK Google, set down light colour on <Rinnai EL> to white
	OK Google, set down light colour on <Rinnai EL> to off
Mood Light On/Off	OK Google, turn on mood light on <Rinnai EL>
	OK Google, turn off mood light on <Rinnai EL>
Mood Light Colour	OK Google, set mood light colour on <Rinnai EL> to 1 (or 2 - 14)
	OK Google, set mood light colour on <Rinnai EL> to off
Sound Effect On/Off	OK Google, turn on sound on <Rinnai EL>
	OK Google, turn off sound on <Rinnai EL>
Volume	OK Google, mute <Rinnai EL>
Timer	OK Google, set timer on <Rinnai EL> to 30 minutes (or half an hour, 1 hour, 2 hours, etc)
	OK Google, cancel timer on <Rinnai EL>
Set Room Temperature	OK Google, set <Rinnai EL> temperature to N Celsius (N=5-40)
	OK Google, set <Rinnai EL> temperature to N Fahrenheit (N=41-104)
ECO On/Off	OK Google, turn on ECO on <Rinnai EL>

Google Device	
Function	Command
Fireplace On/Off	Alexa, turn on <Rinnai EL>
	Alexa, turn off <Rinnai EL>
Flame On/Off	Alexa, turn on flame on <Rinnai EL>
	Alexa, turn off flame on <Rinnai EL>
Flame Mode (Auto/Manual)	Alexa, set flame mode on <Rinnai EL> to auto
	Alexa, set flame mode on <Rinnai EL> to manual
Heater On/Off	Alexa, turn on heater on <Rinnai EL>
	Alexa, turn off heater on <Rinnai EL>
Heater (Auto/Low/High)	Alexa, set heat mode on <Rinnai EL> to auto
	Alexa, set heat mode on <Rinnai EL> to low
	Alexa, set heat mode on <Rinnai EL> to high
My Flame Preset	Alexa, set my favourite flame on <Rinnai EL> to 1 (or 2 - 9)
Flame Colour	Alexa, set flame colour on <Rinnai EL> to 1 (or 2, 3, 4)
	Alexa, set flame colour on <Rinnai EL> to off
Flame Height	Alexa, set flame height on <Rinnai EL> to low
	Alexa, set flame height on <Rinnai EL> to high
Sparks On/Off	Alexa, turn on sparks on <Rinnai EL>
	Alexa, turn off sparks on <Rinnai EL>
Fuel Bed Colour	Alexa, set fuel bed colour on <Rinnai EL> to 1 (or 2 - 9)
	Alexa, set fuel bed colour on <Rinnai EL> to off
Glowing Logs Colour	Alexa, set glowing logs colour on <Rinnai EL> to 1 (or 2 - 9)
	Alexa, set glowing logs colour on <Rinnai EL> to off
Down Light Colour	Alexa, set down light colour on <Rinnai EL> to orange
	Alexa, set down light colour on <Rinnai EL> to white
	Alexa, set down light colour on <Rinnai EL> to off
Mood Light On/Off	Alexa, turn on mood light on <Rinnai EL>
	Alexa, turn off mood light on <Rinnai EL>
Mood Light Colour	Alexa, set mood light colour on <Rinnai EL> to 1 (or 2 - 14)
	Alexa, set mood light colour on <Rinnai EL> to off
Sound Effect On/Off	Alexa, turn on sound on <Rinnai EL>
	Alexa, turn off sound on <Rinnai EL>
Volume	Alexa, turn up volume on <Rinnai EL>
	Alexa, turn down volume on <Rinnai EL>
Set Room Temperature	Alexa, set <Rinnai EL> to 5-104
	Alexa, make it warmer in here
	Alexa make it cooler in here
ECO On/Off	Alexa, turn on ECO on <Rinnai EL>

CLEANING & REPAIRS

CLEANING



ALWAYS DISCONNECT THE APPLIANCE FROM THE POWER SUPPLY AND ALLOW TO COOL BEFORE CLEANING.

Your appliance needs very little maintenance, however it should be regularly cleaned using a dry cloth. Do not use detergents, abrasive cleaners or furniture polish.

To clean the glass, use a lightly damp cloth and ensure any moisture is dried fully using a lint free cloth.

Ensure the heater vent is kept dust free by regularly (monthly or more frequently) vacuuming the vent area with a brush attachment. This will keep it working efficiently.

REPAIRS

Repairs MUST be carried out by a qualified person such as an electrician.

TROUBLE SHOOTING CHECKLIST

Resetting the Thermal Cut Out

The appliance is fitted with an Electronic Safety Control (E.S.C). This is a safety device which switches off the fire if, for any reason, the appliance overheats, e.g. when covered. If the heater stops operating while the flame effect continues working normally, this indicates that the E.S.C is in operation. The E.S.C can only be reset after the appliance has cooled down and the appliance has been reset. Re-setting of the E.S.C Resetting procedure for the E.S.C is as follows:

1. Make sure that the power supply is disconnected with the plug socket outlet. Switch off the appliance via the On/Off switch on the Manual Control. Then leave it off for approximately 10-15 minutes.
2. Remove any obstruction to the fan heater outlet or fan blades etc.
3. Re-connect the power supply, and switch on the appliance and the E.S.C will be reset.
4. Ensure that the appliance is functioning correctly. If the E.S.C operates again, the appliance and wiring should be checked by a qualified person such as an electrician.

Use the following chart to help determine whether a service call is required. However, if you are unsure about the way your heater is operating, or if you have any other faults or problems, please refer to your installer or a Rinnai Customer Care Centre Consultant, see back page for Rinnai website and contact details.

Problem	Probable Cause	Suggested Remedy
Appliance will not turn on.	Problem with power supply.	<p>Check that the appliance is plugged in to the power supply and switched on.</p> <p>Check and replace fuse in the plug if necessary.</p> <p>Check that the main power switch on the appliance is turned on.</p>
Remote control does not work.	Batteries have expired.	Replace batteries.
	Remote has not synced with appliance.	Ensure that the appliance is turned on. Re-sync the remote by pressing the – button and the + button at the same time and holding for 3 seconds.
No heat.	Incorrect thermostat setting.	Increase the desired temperature higher than the current room temperature.
	Overheating may have engaged the E.S.C feature.	See above for E.S.C reset procedure.
Appliance turns off before desired temperature is reached.	Open window detection has activated.	Check that any windows in the room are closed.
	Remote Control is in unsuitable location.	Relocate remote control in the same room as the appliance.

INSTALLATION TABLE OF CONTENTS

Operation Table of Contents	3
General Installation Information	18
Installation Requirements	18
Unpacking the Appliance	18
Carton Contents	18
Before You Start	22
Appliance Location	22
Clearances	22
Installation	23
Stud/Feature Wall	23
Electrical Connections	23
GPO Connection	23
Heater Installation	23
Preparing the Appliance	24
Glass Removal - Accessing Parts	24
Aspect Type	25
One-Sided (Front) Aspect	25
Two-Sided (Corner) Aspect	25
Three-Sided Aspect	25
Power Cord	26
Fuel Bed Uplights	26
Anti Vibration Mounts	26
Fuel Bed Setup - EL1000	27
Fuel Bed Setup - EL1300 & EL1500	31
Fuel Bed Setup - EL1800	37
Fuel Bed Setup - EL1800	38
Specifications	43
Product Specifications	43
Technical Information	44
Warranty	45
Contacts	52



For continued safety of this appliance it MUST be installed and maintained in accordance with the manufacturers instructions.

GENERAL INSTALLATION INFORMATION

INSTALLATION REQUIREMENTS

This appliance must be installed in accordance with this instruction manual.

UNPACKING THE APPLIANCE

Check for damage and missing parts. If the heater is damaged or missing any parts, contact your supplier for advice.

CARTON CONTENTS

Item Checklist – EL1000

Ensure that the components listed are present before proceeding with the installation.

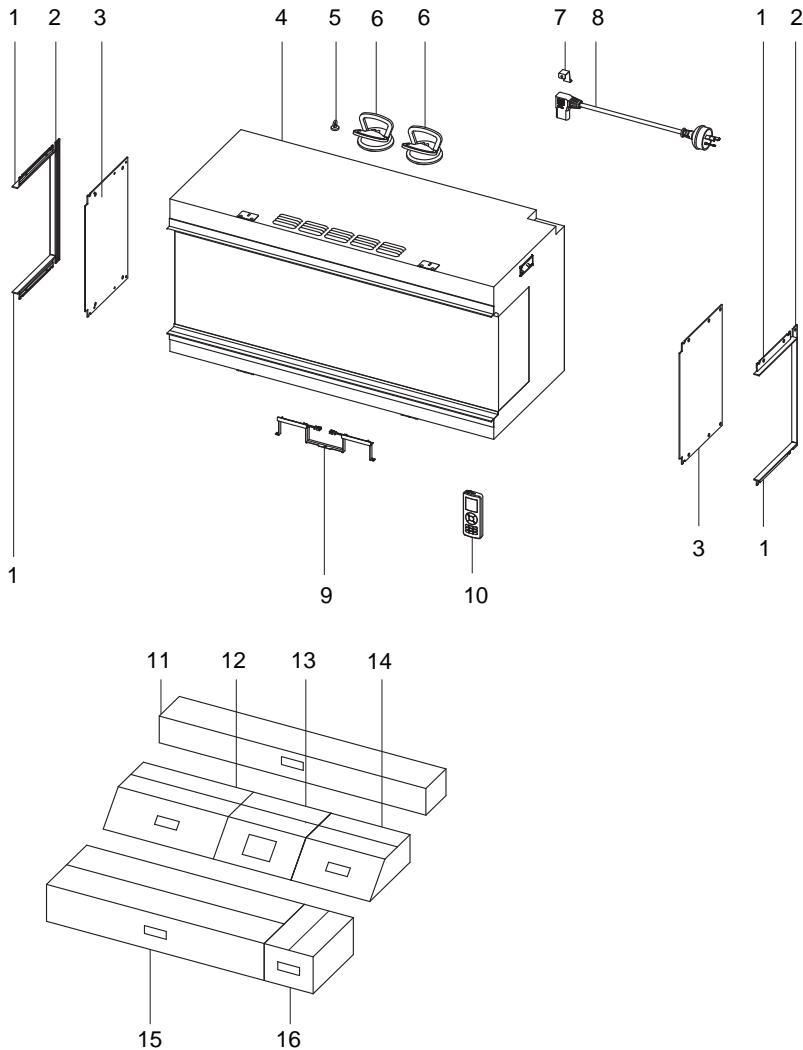

Description	Qty
BOX 1	
User manual/Warranty	1
Remote handset	1
AAA battery	2
Power cord	1
Power cord securing bracket	1
ST4x8 screw	1
ST4x40 screw	1

BOX 2	
Black glass embers	3 bags
Black resin embers	3 bags
Clear resin embers	2 bags
Grey ceramic chips	1 bag
Black ceramic chips	1 bag

BOX 3	
Side glass trim (top/bottom)	4
Side glass trim (side)	2
Back panel uplights	1

Item	Description	Qty	Item	Description	Qty
1	Side Glass Trim (Top/Bottom)	4	9	Back Panel Uplight	1
2	Side Glass trim (side)	2	10	Remote Control Handset	1
3	Side Glass panel	2	11	Box 3	1
4	Appliance	1	12	Box 2	1
5	Magnetic Tool	1	13	Box 1	1
6	Glass Suction Cup	2	14	Log Set B	1
7	Power cord securing bracket	1	15	Log set A	1
8	Power Cord	1	16	Log Set C	1

Item Checklist – EL1300

Ensure that the components listed are present before proceeding with the installation.

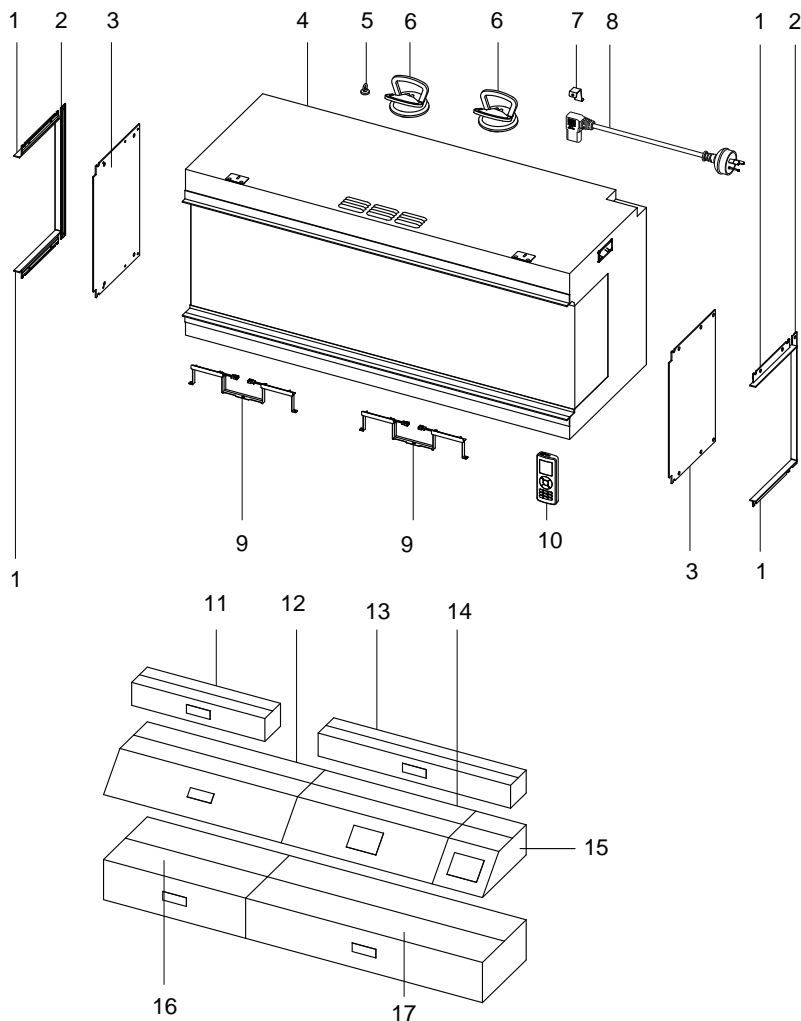

Description	Qty
BOX 1	
User manual/Warranty	1
Remote handset	1
AAA battery	2
Power cord	1
Power cord securing bracket	1
ST4x8 screw	1
ST4x40 screw	1
Side glass trim (top/bottom)	4
Side glass trim (side)	2
Back panel uplights	2

BOX 2	
Black glass embers	2 bags
Grey ceramic chips	1 bag
Black ceramic chips	1 bag

BOX 3	
Clear resin embers	4 bags

BOX 4	
Black resin ember	6 bags

Item	Description	Qty	Item	Description	Qty
1	Side Glass Trim (Top/Bottom)	4	10	Remote Control Handset	1
2	Side Glass trim (side)	2	11	Box 3	1
3	Side Glass panel	2	12	Log Set C	1
4	Appliance	1	13	Box 4	1
5	Magnetic Tool	1	14	Box 1	1
6	Glass Suction Cup	2	15	Box 2	1
7	Power cord securing bracket	1	16	Log Set B	1
8	Power Cord	1	17	Log set A	
9	Back Panel Uplight	2			

Item Checklist – EL1500

Ensure that the components listed are present before proceeding with the installation.

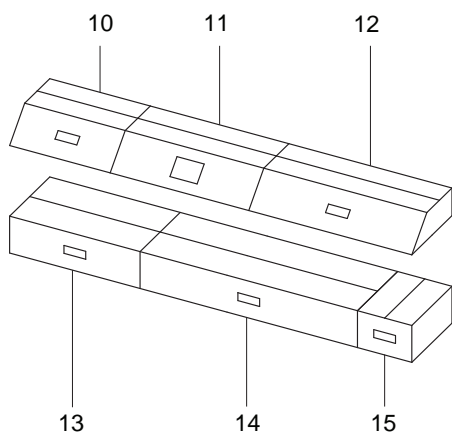
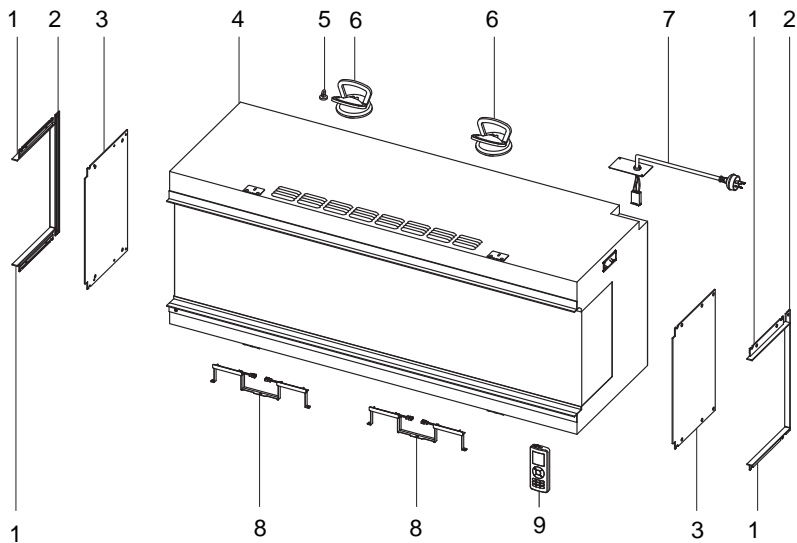

Description	Qty
BOX 1	
Black glass embers	3 bags
Grey ceramic chips	1 bag
Black ceramic chips	1 bag

BOX 2	
User manual/Warranty	1
Remote handset	1
AAA battery	2
Power cord	1
ST4x40 screw	1
Side glass trim (top/bottom)	4
Side glass trim (side)	2
Back panel uplights	2

BOX 3	
Black resin ember	2 bags
Clear resin embers	2 bags

Item	Description	Qty	Item	Description	Qty
1	Side Glass Trim (Top/Bottom)	4	9	Remote Control Handset	1
2	Side Glass trim (side)	2	10	Box 1	1
3	Side Glass panel	2	11	Box 2	1
4	Appliance	1	12	Log set A	1
5	Magnetic Tool	1	13	Log Set B	1
6	Glass Suction Cup	2	14	Log Set C	1
7	Power Cord	1	15	Box 3	1
8	Panel Uplight	2			

Item Checklist – EL1800

Ensure that the components listed are present before proceeding with the installation.

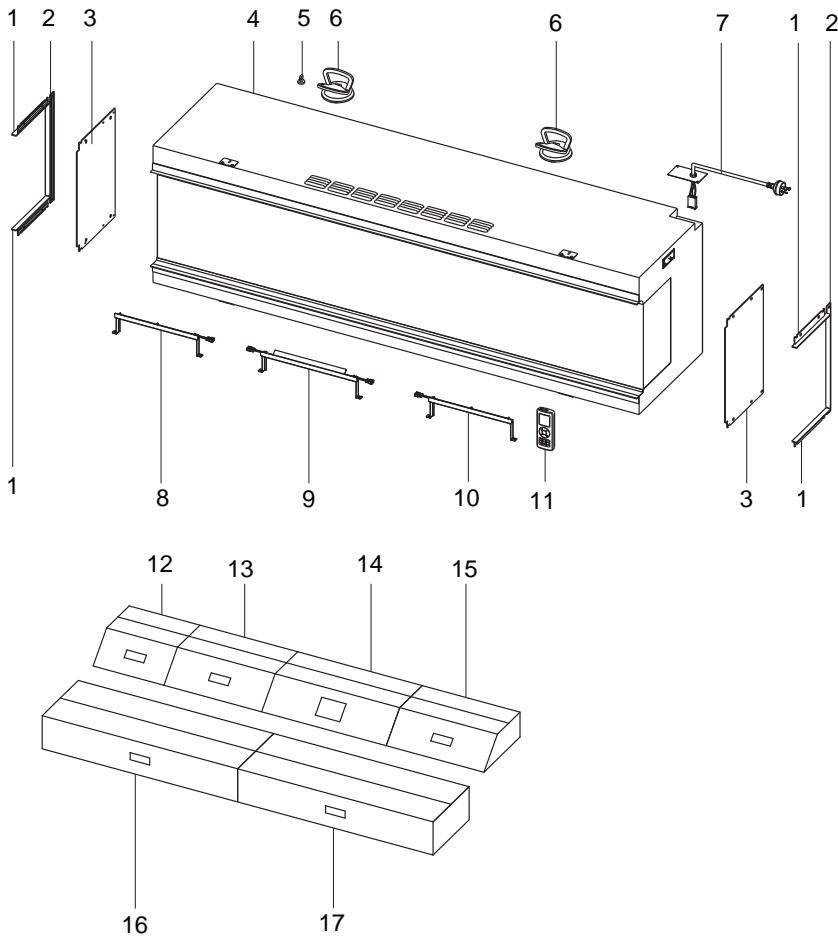

Description	Qty
BOX 1	
User manual/Warranty	1
Remote handset	1
AAA battery	2
Power cord	1
ST4x40 screw	1
Tape	1
Side glass trim (top/bottom)	4
Side glass trim (side)	2
Back panel uprights	3

BOX 2	
Black glass embers	3 bags
Grey ceramic chips	1 bag
Black ceramic chips	1 bag

BOX 3	
Black resin ember	2 bags
Clear resin embers	2 bags

Item	Description	Qty	Item	Description	Qty
1	Side Glass Trim (Top/Bottom)	4	10	Back Panel Uplight C	1
2	Side Glass trim (side)	2	11	Remote Control Handset	1
3	Side Glass panel	2	12	Box 2	1
4	Appliance	1	13	Box 3	1
5	Magnetic Tool	1	14	Box 1	1
6	Glass Suction Cup	2	15	Log Set C	1
7	Power Cord	1	16	Log Set B	1
8	Back Panel Uplight A	1	17	Log set A	1
9	Back Panel Uplight B	1			

BEFORE YOU START

APPLIANCE LOCATION

The main considerations when positioning the heater are:

- Ensuring all minimum clearance requirements as shown are met.
- Allowing sufficient access for ease of operation, servicing and removal of the appliance.
- Ensuring the 3 pin plug is accessible and connected to a dedicated 220-240 V, 50 Hz, 10 Amp for EL1300 and 15 Amp for EL1500, earthed power point supplied from mains electricity. The connection of the appliance to a permanent electrical supply (hard-wiring) and the installation of any other electrical wiring, power outlets and switches **MUST** be performed by a person authorised under the legislation of your local electrical authority, such as a licensed electrician.
- Ensure any wall cavities above the heater are blocked off to avoid heat loss and poor heating performance. If installing in an existing fireplace, chimney or wall cavity, always block off the space above and around the heater to prevent heat loss and undesirable drafts. Failure to do this may cause the appliance to cut out.

CLEARANCES

The minimum clearances shown **MUST** be maintained.

Minimum Clearance to Combustibles (mm)		
Sides	0	No clearance required
Floor	0	
Back	0	
Top (shelf or TV)	200	
Front	915	

Dimensions for Cavity Installation					
Model	Recommended Cavity Dimensions (mm)*				
	H	W			D
		One-sided (a)	Two-sided (b)	Three-sided (c)	
EL1000	595	1010	1010	1010	525
EL1300	595	1310	1310	1310	525
EL1500	595	1510	1510	1510	525
EL1800	595	1810	1810	1810	525

*These dimensions are a guide. Always measure the appliance on site before cutting the cavity.

Figure 3. Clearance to Combustibles

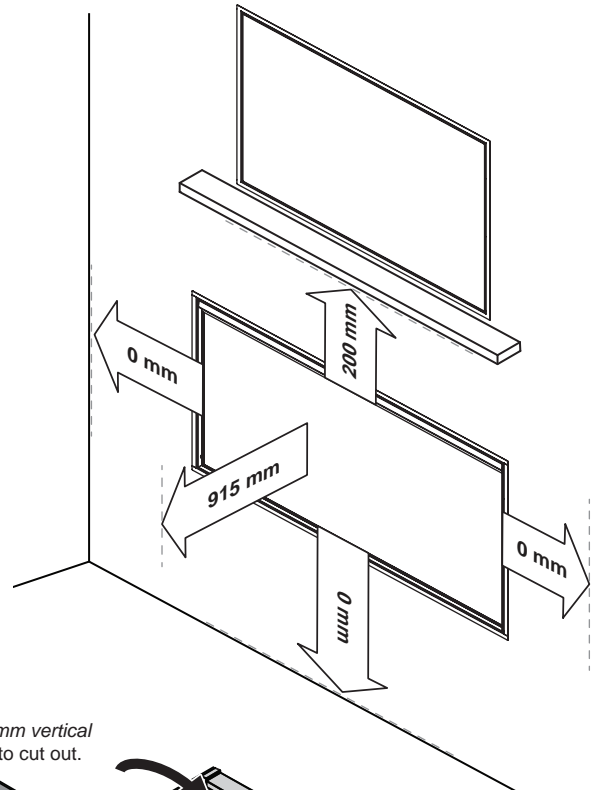
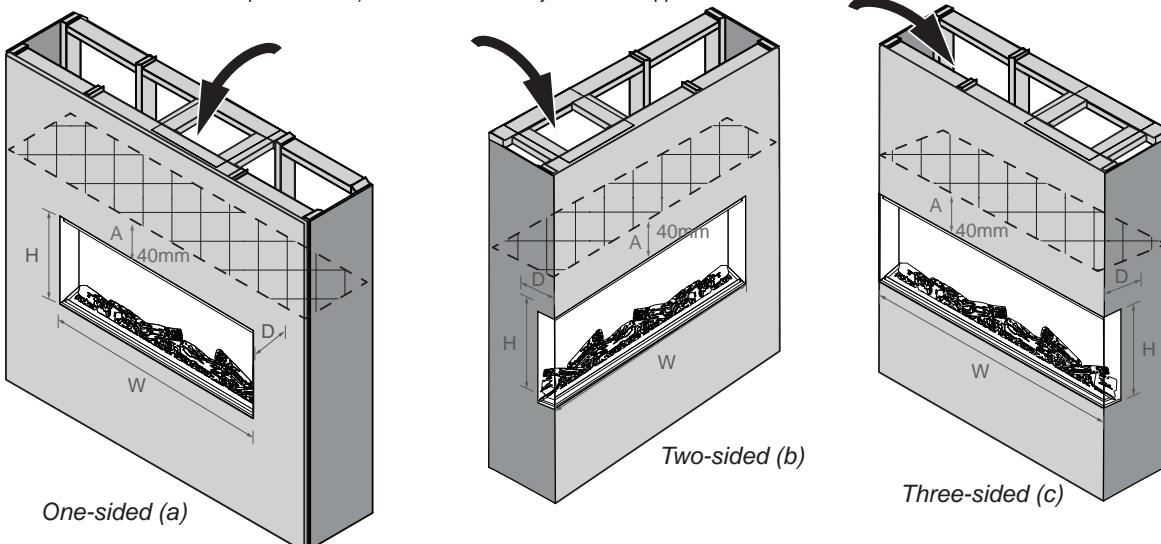

Figure 4. Cavity Dimensions

To avoid heat loss and draft, block off space above heater (ensuring 40mm vertical clearance to top of heater A). Failure to do so may cause the appliance to cut out.



STUD/FEATURE WALL

The manufacturer does not accept any liability for any injuries or damages that may occur due to improper handling or installation. Ensure that the wall upon which the appliance is to be installed and any wall fixings used are sufficiently strong enough to hold the weight of the appliance. Plasterboard alone is not considered a structural material and it is not recommended to rely solely on plasterboard fittings to support the weight of the appliance.

If the appliance or any structure linked to the appliance is to be fitted to a wall with a timber frame construction, adequate wooden supporting members must be fitted using appropriate fixings. If this is not possible then steps must be taken to strengthen the wall before installation.

When creating a timber framework, a minimum thickness of 50mm timber must be used.

There are four framing plates fixed to the appliance: two along the top front edge and two along the bottom front edge. Bend these at an angle of 90 degrees to the appliance, then secure to the timber framework using the four timber screws provided.

Figure 5.

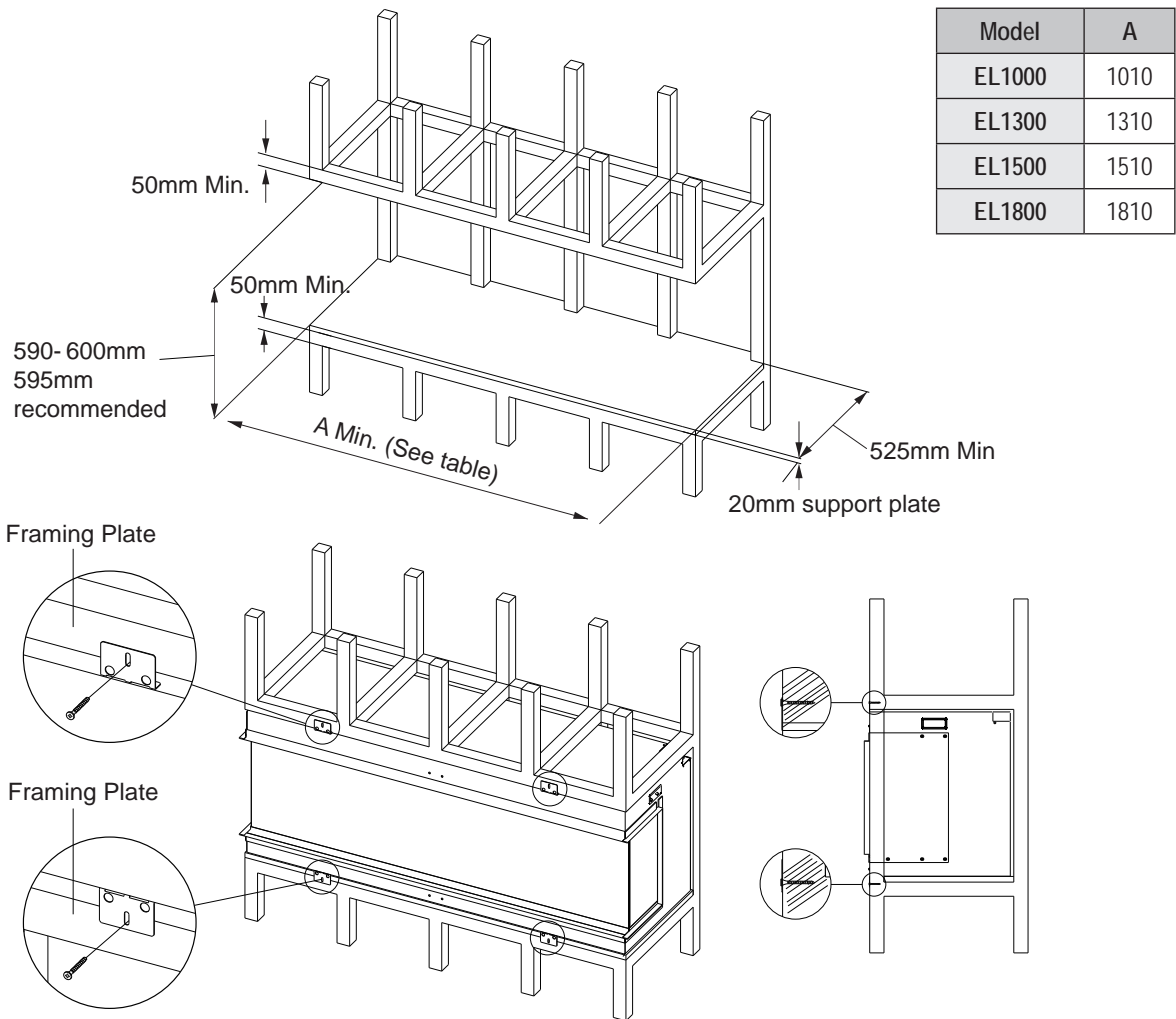

ELECTRICAL CONNECTIONS

GPO Connection

The connection of the appliance to a permanent electrical supply (hard-wiring) and the installation of any other electrical wiring, power outlets and switches **MUST** be performed by a person authorised under the legislation of your local electrical authority, such as a licensed electrician.

HEATER INSTALLATION

Before installation, check that all parts are included and undamaged. If the appliance is damaged, check with the supplier before installation and operation. If the mains power supply lead is damaged in any way, it **MUST** be replaced by a suitable equivalent approved by the manufacturer.

The main box contains the appliance, 2 x Suction Cups and 1 x magnet tool. Packed with the appliance (behind the glass panel) are additional boxes each with a contents list printed on the outside of each box.

PREPARING THE APPLIANCE

It is recommended that you prepare the appliance in the final place of intended installation, secured to any necessary framework or stud work. Any movement after preparation may result in the movement of the precisely arranged fuel bed elements.

Glass Removal - Accessing Parts

To gain access to various contents required for installation, follow these steps:

- Step 1. Remove the transit bar from the front of the appliance. Re-fit the screws to the appliance and discard of the transit bar – Figure 6.
- Step 2. Using the magnetic tool, attach to the glass retaining bar situated in front of the glass panel and lift up and away from the appliance to reveal the channel below – Figure 7.

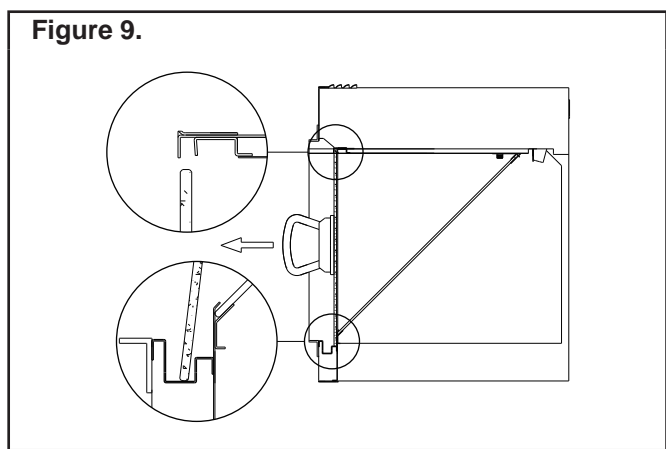
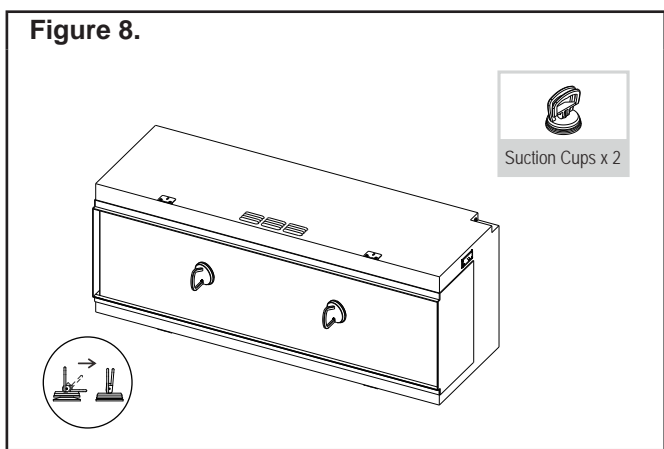
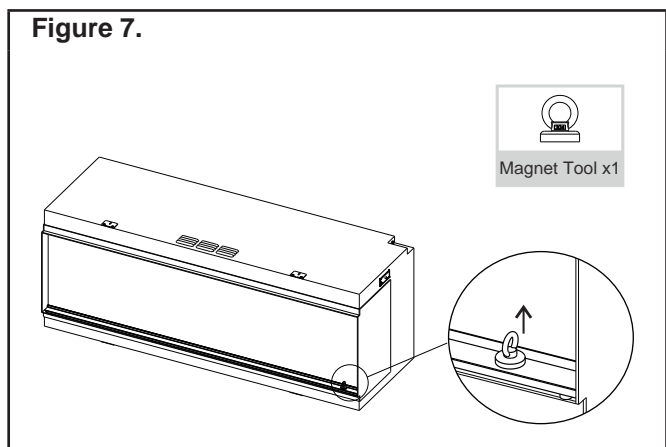
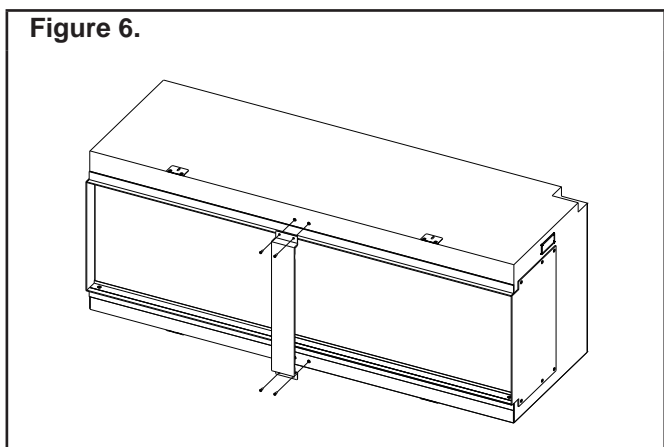

- Step 3. Using the 2 Glass Suction Cups provided, lift the glass outwards and carefully guide the bottom edge into the channel. Angle the top edge of the glass away from the appliance and lift out. Place aside in a safe location – Figure 8 & Figure 9.
- Step 4. To remove the angled glass panel, locate the two steel plate brackets that are secured using a thumbscrew; one at each top corner of the glass. Turn the thumb screws anti-clockwise and remove the brackets.
Using the 2 Glass Suction Cups provided, first lift the glass upwards, then carefully guide the bottom edge upwards and out of the appliance. Place aside in a safe location – Figure 10 on page 25.

The component boxes and cardboard inserts can now be safely removed from the appliance. Take care not to damage the LCD screen in the ceiling of the appliance when removing the items.

When replacing the angled glass panel, the correct surface must be facing upwards. See the stickers on the glass panel for guidance. Replace the glass in the reverse order to initial removal, ensuring that both steel plate brackets are fitted and secured using the thumbscrews.

Figure 10.

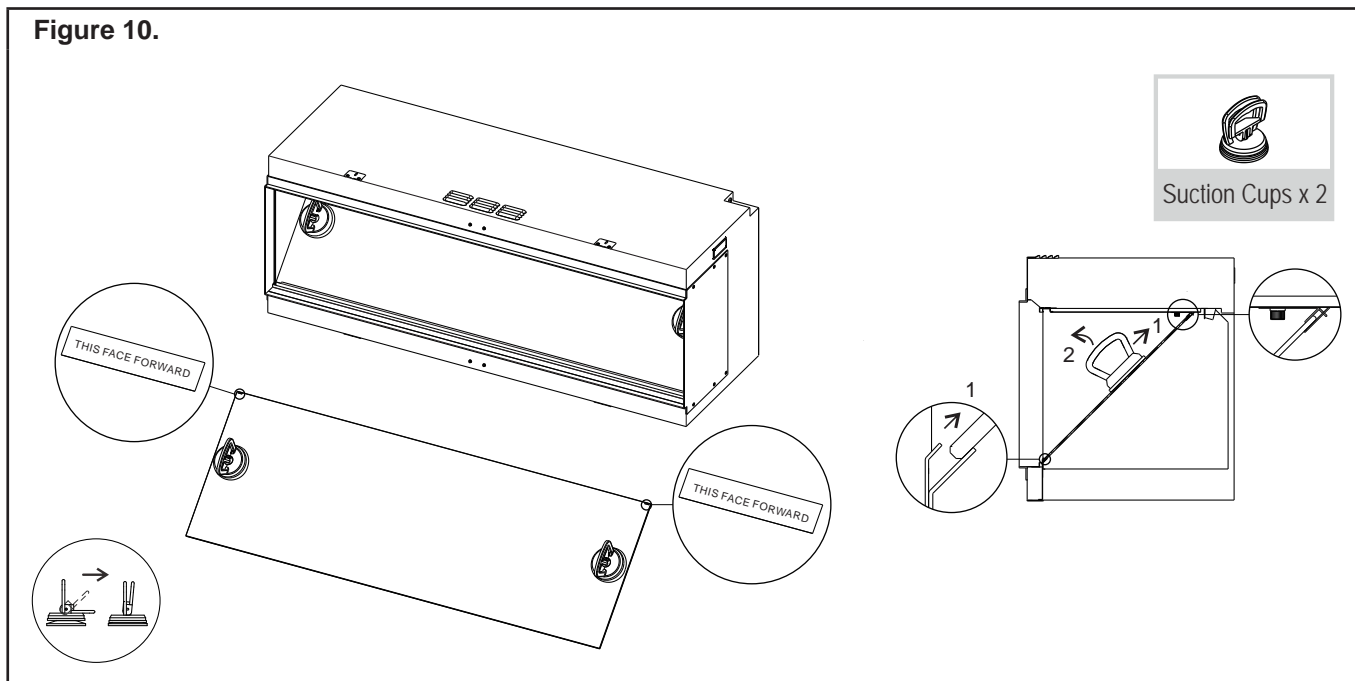

ASPECT TYPE

The appliance can be installed in three different aspects:

- Front (1 glass panel)
- Corner (2 glass panels)
- Three-sided (3 glass panels)

One-Sided (Front) Aspect

Your appliance will arrive in a single-sided (front only) aspect with metal side panels already fitted.

Two-Sided (Corner) Aspect

For a two-sided (corner) aspect, choose which side you want to feature a glass panel and remove the 6 screws that secure the metal side panel to the appliance. Carefully remove the panel and keep the screws in a safe place. Using the removed screws, take **2 top/bottom** side glass edge trims and **1 side** glass edge trim and screw them to the appliance as shown on Figure 12 & Figure 13.

Three-Sided Aspect

For a three-sided aspect, repeat the corner aspect procedure on the opposite side of the appliance. Refer to Figure 12 & Figure 13.

Figure 11.

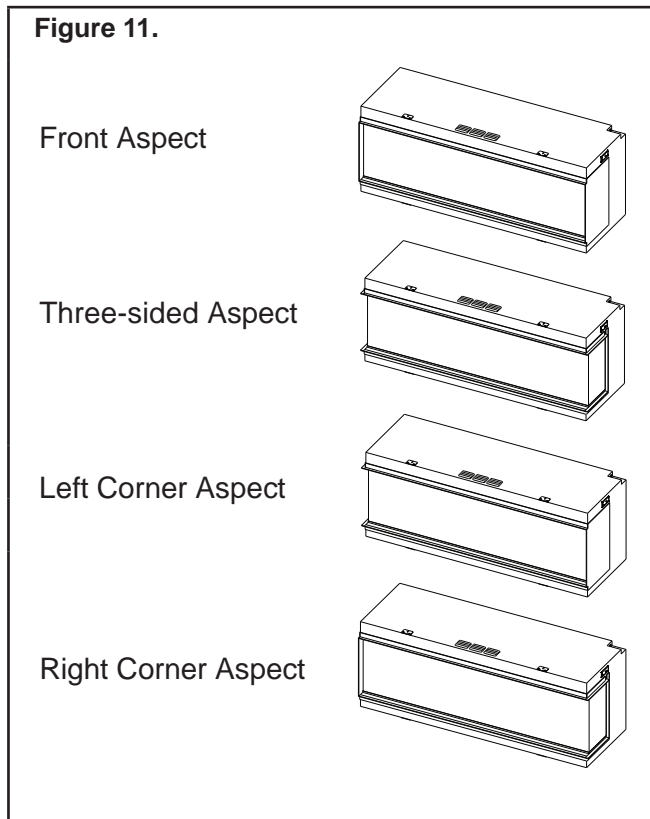

Figure 12.

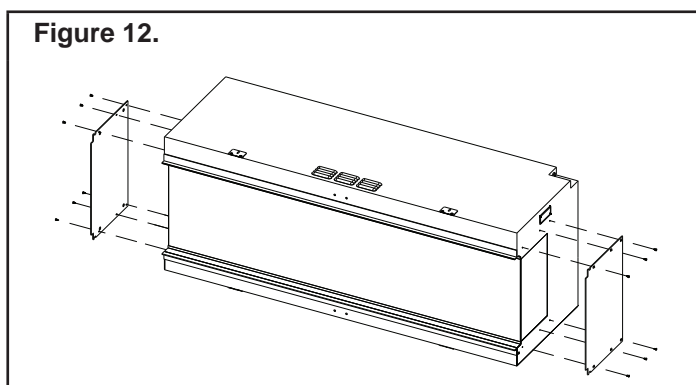
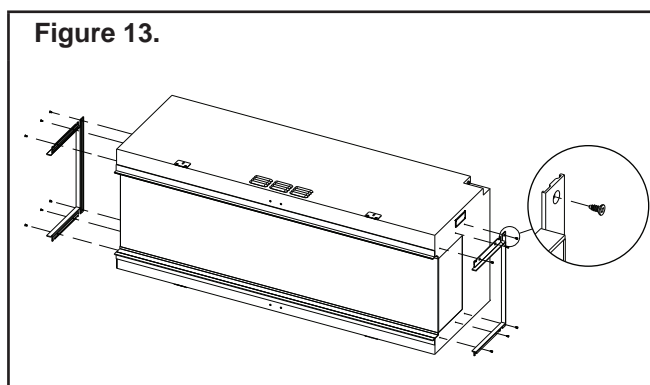

Figure 13.





The manufacturer does not accept any liability for any injuries or damages that may occur due to improper handling or installation. Ensure that the wall where the appliance is to be installed and any wall fixings used are sufficiently strong enough to hold the weight of the appliance. The appliance weight can be found printed on the packaging.

Plasterboard alone is not considered a structural material and it is not recommended to rely solely on plasterboard fittings to support the weight of the appliance.

If the appliance or any structure linked to the appliance is to be fitted to a wall with a timber frame construction, adequate wooden supporting members must be fitted using appropriate fixings. If this is not possible then steps must be taken to strengthen the wall before installation.

Power Cord

After inserting the 1.8m power cord into the socket on the bottom right side of the appliance, secure in place using the power cord securing bracket and ST4*8 screw. Refer to Figure 14.

Fuel Bed Uplights

With the front glass panel and angled glass panel removed from the appliance, take the two Fuel Bed Uplights and secure in place on the fuel bed using the thumbscrews provided. Figure 15.



If not secured, the connection can become loose during installation which may present a hazard (sparking etc.)

Ensure the power cord is not squashed, kinked or in contact with hot or sharp surfaces.

Do not route the power lead in front of the appliance.

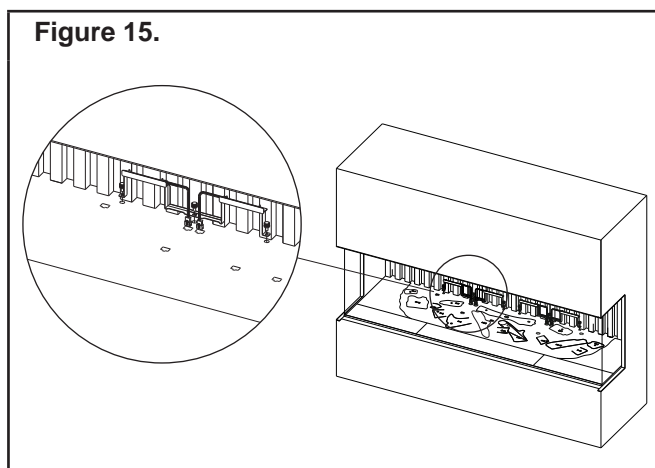
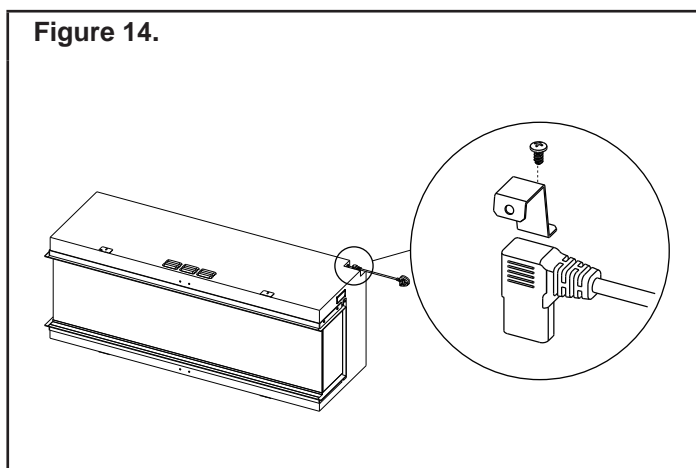

Anti Vibration Mounts

During the installation of the appliance onto a wooden frame or hardened surface, it is recommended for the installer to incorporate measures that mitigate the vibrations generated by the motors. The anti-vibration material should be strategically positioned on the appliance’s support base and at each point where the appliance is supported to ensure that the level of the appliance is not compromised.

The design of this can be applied as a comprehensive gasket or in separate sections, as deemed by the installer. Neglecting this step could lead to an elevated noise level when the motors are in operation.

It is important to note that this installation detail cannot be applied retrospectively after the feature has been finished and must be carried out during the early stages of the installation process.

FUEL BED SETUP - EL1000



For fuel bed setup of the EL1000 only. The logs and other fuel elements provided with the appliance must be installed in the exact locations and positions described in the steps below. Failure to install the logs correctly will result in an impaired flame effect.

All logs and fuel elements are marked with an individual code. The fuel bed is also marked with the same corresponding code and accompanying stencilled outline. Most of the logs feature a small peg on the underside that will slot into a corresponding hole on the fuel bed.



Five of the logs feature internal LED illumination. These need to be plugged into ports located on the fuel bed. **Take care not to damage the connector pins at this point as it may result in malfunction.**

Follow the sequence steps detailed below. For further assistance, scan the QR code to access a video guide.

Step 1. Ensure that both back panel up-lights are installed and connected. Use the thumbscrews provided to secure the lights, and ensure the cables are plugged into the connectors on the fuel bed.

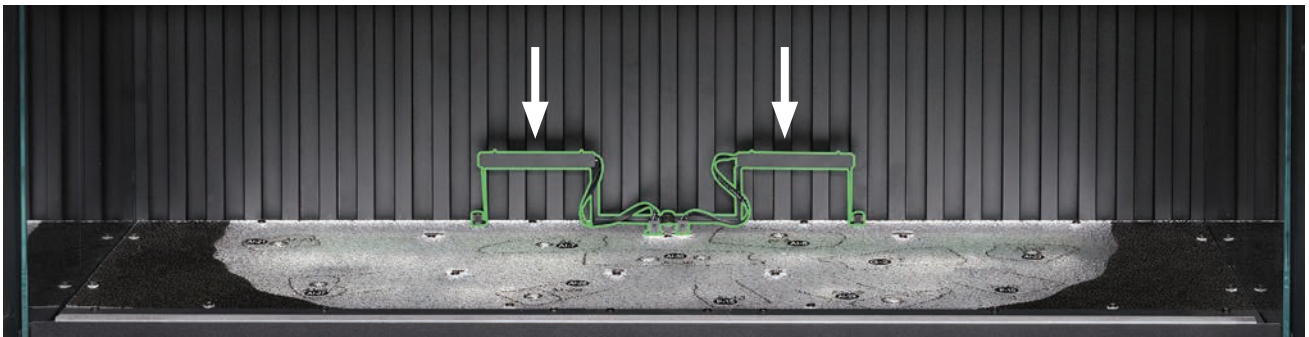

Step 2. Position log AI-7 and AI-8 onto the corresponding outline on the fuel bed, locating the peg on the underside of the log into the hole in the fuel bed.

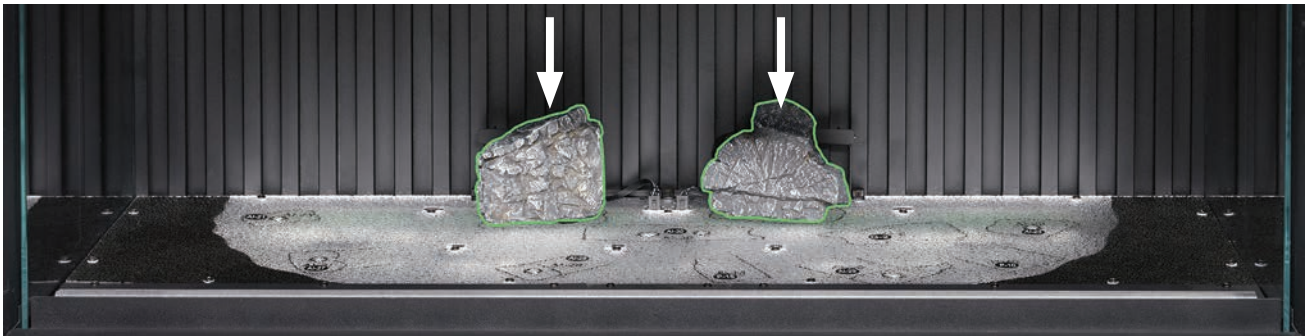

Step 3. Position log AI-30 onto the corresponding outline on the fuel bed, locating the peg on the underside of the log into the hole in the fuel bed.

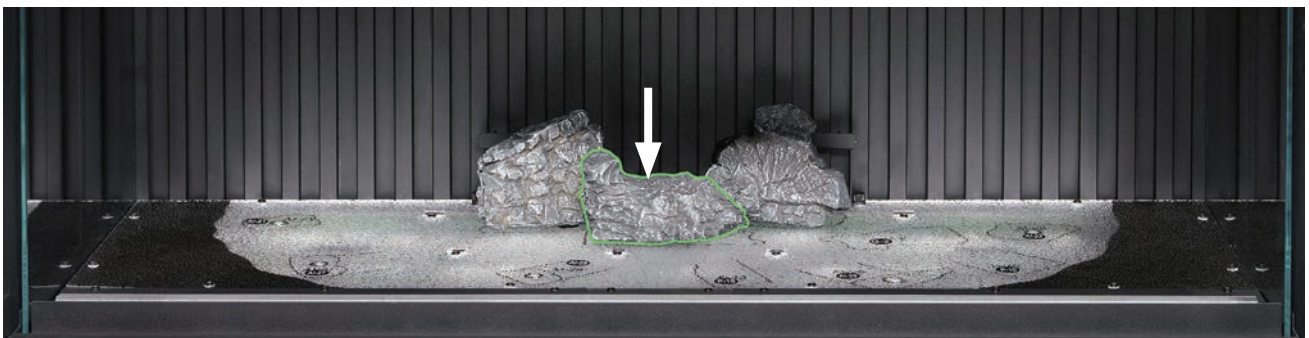

Step 4. Position log AI-21 onto the corresponding outline on the fuel bed, locating the peg on the underside of the log into the hole in the fuel bed, and plug the cable into the connector on the fuel bed.



Step 5. Position log AI-23 onto the corresponding outline on the fuel bed, locating the peg on the underside of the log into the hole in the fuel bed, and plug the cable into the connector on the fuel bed.



Step 6. Position log AI-27 and G2 onto the corresponding outline on the fuel bed, locating the peg on the underside of the log into the hole in the fuel bed, and plug the cable into the connector on the fuel bed.



Step 7. Position log P-10 onto the corresponding outline on the fuel bed.



Step 8. Position log AI-29 and P15 onto the corresponding outline on the fuel bed, locating the peg on the underside of the log into the hole in the fuel bed, and plug the cable into the connector on the fuel bed.



Step 9. Position log AI-28 onto the corresponding outline on the fuel bed, locating the peg on the underside of the log into the hole in the fuel bed, and plug the cable into the connector on the fuel bed.



Step 10. Distribute the clear resin embers around the base of the logs, placing them inside the clear area of the fuel bed. Ensure good coverage, including areas underneath the raised logs.



Step 11. Distribute the black resin embers around the base of the logs, placing them inside the black area of the fuel bed. Ensure good coverage.



Step 12. Distribute the black glass embers around the entire fuel bed, placing them over both clear and black resin embers. Do not feel that you need to use all of the black glass embers provided. At this stage it may be helpful to turn on the appliance to illuminate the fuel bed and review the coverage of embers.

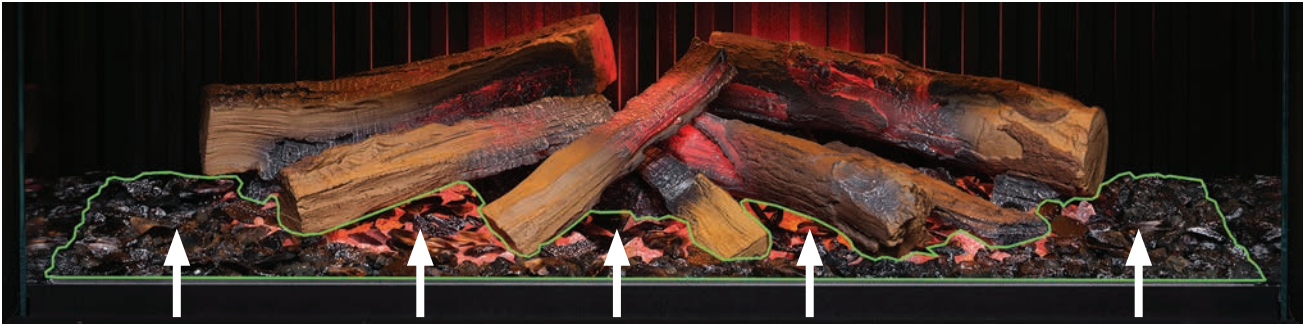

Step 13. Take the remaining small logs and bark pieces and arrange them randomly around the fuel bed, pressing them down into the embers. The small pieces of bark can be used to conceal any visible wires.



Step 14. Distribute the grey and black slate chips around the fuel bed. Finally, re-fit the flame screen ensuring the correct surface is forward and check for proper alignment of flames on the logs.



The logs and other fuel elements provided with the appliance must be installed in the exact locations and positions described in these steps. Failure to install the logs correctly will result in an impaired flame effect.



When the appliance is turned on for the first time, the fuel bed will flash orange for a short time. This indicates that the appliance is warming up. The flashing will cease after approximately 10 seconds and the flame effect will activate.

For further assistance, scan the QR code to access a video guide showing how to successfully install the fuel bed.

Complete the setup by carefully re-fitting the front glass using the suckers provided, then re-fit the glass retaining bar following the steps detailed on page 24 in reverse.



FUEL BED SETUP - EL1300 & EL1500



For fuel bed setup of the EL1300 & EL1500 only. The logs and other fuel elements provided with the appliance must be installed in the exact locations and positions described in the steps below. Failure to install the logs correctly will result in an impaired flame effect. .

All logs and fuel elements are marked with an individual code. The fuel bed is also marked with the same corresponding code and accompanying stencilled outline. Most of the logs feature a small peg on the underside that will slot into a corresponding hole on the fuel bed.



Six of the logs feature internal LED illumination. These need to be plugged into ports located on the fuel bed. Take care not to damage the connector pins at this point as it may result in malfunction.

Follow the sequence steps detailed below. For further assistance, scan the QR code to access a video guide.

Step 1. Ensure that both back panel up-lights are installed and connected. Use the thumbscrews provided to secure the lights, and ensure the cables are plugged into the connectors on the fuel bed.

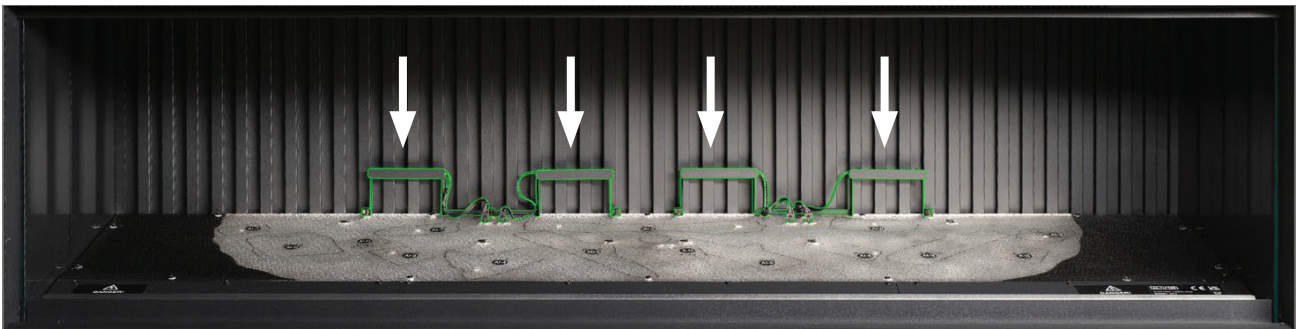

Step 2. Position log AI-2 onto the corresponding outline on the fuel bed, locating the peg on the underside of the log into the hole in the fuel bed.

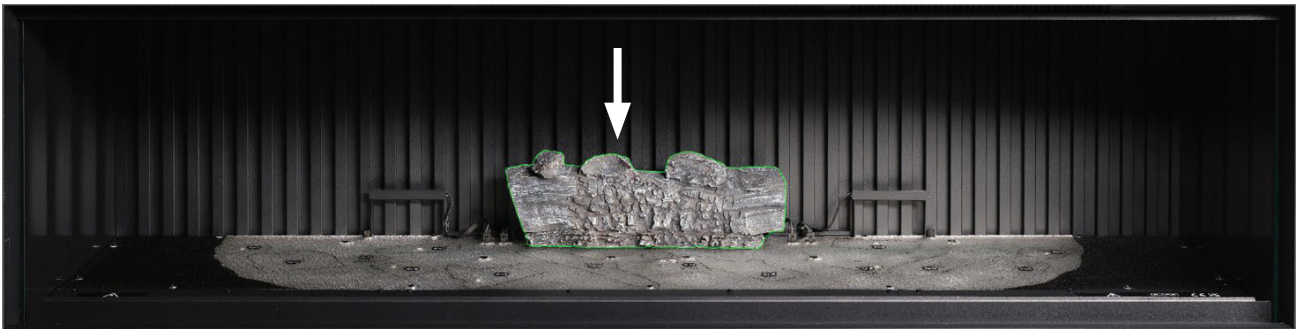

Step 3. Position log AI-7 onto the corresponding outline on the fuel bed, locating the peg on the underside of the log into the hole in the fuel bed.



Step 4. Position log AI-8 onto the corresponding outline on the fuel bed, locating the peg on the underside of the log into the hole in the fuel bed.



Step 5. Position log AI-1 onto the corresponding outline on the fuel bed, locating the peg on the underside of the log into the hole in the fuel bed, and plug the cable into the connector on the fuel bed.



Step 6. Position log AI-3 onto the corresponding outline on the fuel bed, locating the peg on the underside of the log into the hole in the fuel bed, and plug the cable into the connector on the fuel bed.



Step 7. Position log AI-9 onto the corresponding outline on the fuel bed, locating the peg on the underside of the log into the hole in the fuel bed, and plug the cable into the connector on the fuel bed.

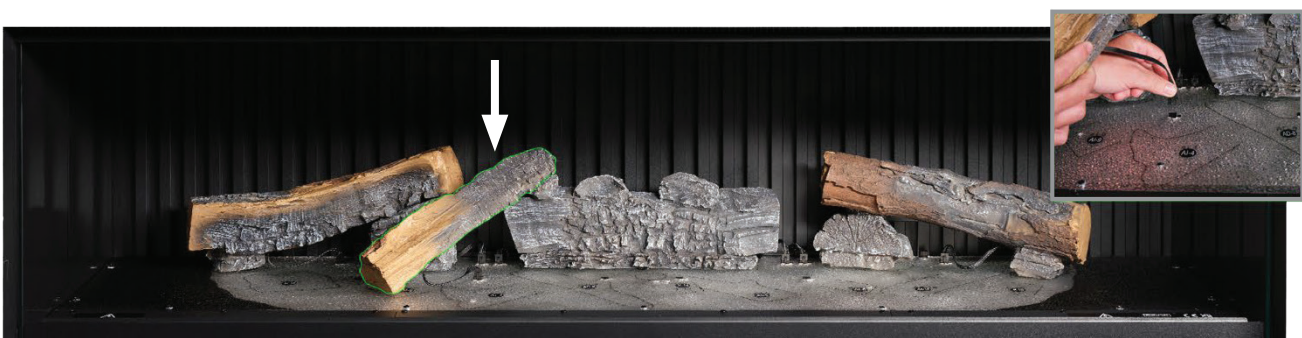

Step 8. Position log AI-10 onto the corresponding outline on the fuel bed.



Step 9. Position log AI-11 onto the corresponding outline on the fuel bed.



Step 10. Position log AI-6 onto the corresponding outline on the fuel bed, locating the peg on the underside of the log into the hole in the fuel bed, and plug the cable into the connector on the fuel bed.

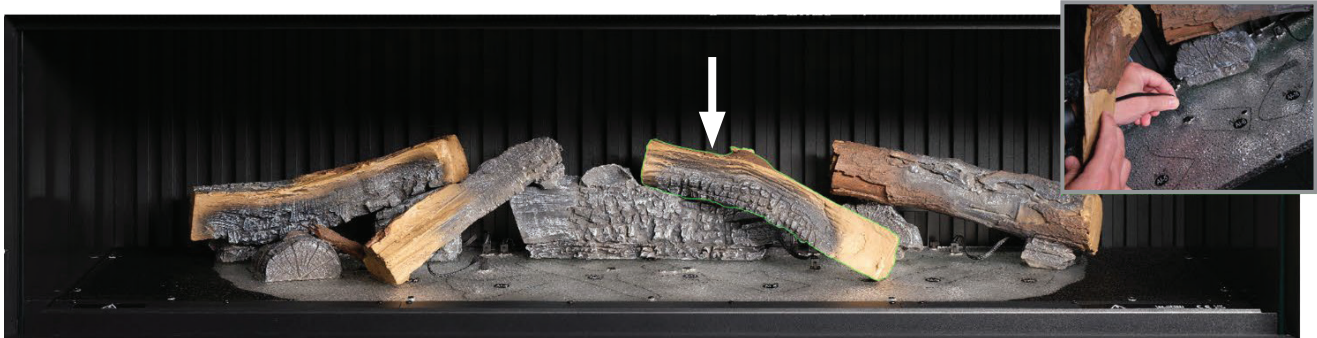

Step 11. Position log AA-16 onto the corresponding outline on the fuel bed.



Step 12. Position log P-10 onto the corresponding outline on the fuel bed.



Step 13. Position log AI-4 onto the corresponding outline on the fuel bed, locating the peg on the underside of the log into the hole in the fuel bed, and plug the cable into the connector on the fuel bed.

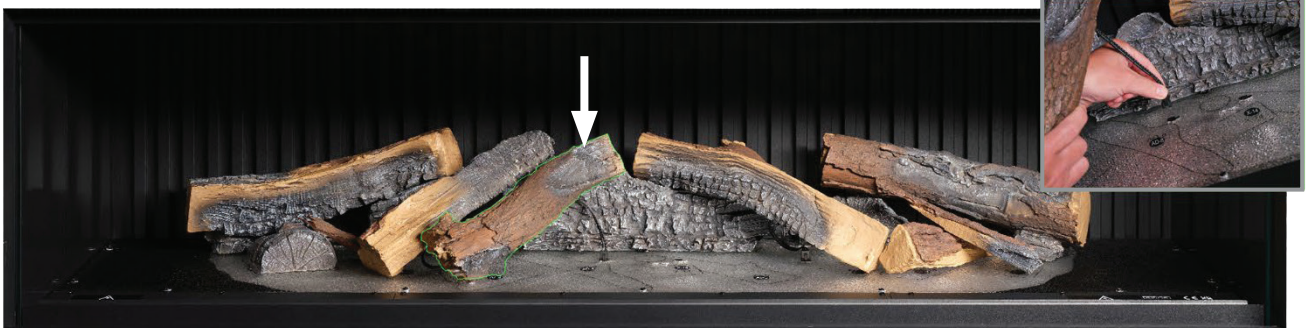

Step 14. Position log AI-5 onto the corresponding outline on the fuel bed and plug the cable into the connector on the fuel bed.



Step 15. Position log AD-8 onto the corresponding outline on the fuel bed.



Step 16. Position log X-14 onto the corresponding outline on the fuel bed.



Step 17. Distribute the clear resin embers around the base of the logs, placing them inside the clear area of the fuel bed. Ensure good coverage, including areas underneath the raised logs.



Step 18. Distribute the black resin embers around the base of the logs, placing them inside the black area of the fuel bed. Ensure good coverage.



Step 19. Distribute the black glass embers around the entire fuel bed, placing them over both clear and black resin embers. Do not feel that you need to use all of the black glass embers provided.



Step 20. At this stage it may be helpful to turn on the appliance to illuminate the fuel bed and review the coverage of embers.



Step 21. Take the remaining small logs and bark pieces and arrange them randomly around the fuel bed, pressing them down into the embers. The small pieces of bark can be used to conceal any visible wires.



Step 22. Distribute the grey and black slate chips around the fuel bed. Finally, re-fit the flame screen ensuring the correct surface is forward and check for proper alignment of flames on the logs.



The logs and other fuel elements provided with the appliance must be installed in the exact locations and positions described in these steps. Failure to install the logs correctly will result in an impaired flame effect.



When the appliance is turned on for the first time, the fuel bed will flash orange for a short time. This indicates that the appliance is warming up. The flashing will cease after approximately 10 seconds and the flame effect will activate.

For further assistance, scan the QR code to access a video guide showing how to successfully install the fuel bed.

Complete the setup by carefully re-fitting the front glass using the suckers provided, then re-fit the glass retaining bar following the steps detailed on page 24 in reverse.



FUEL BED SETUP - EL1800



For fuel bed setup of the EL1800 only. The logs and other fuel elements provided with the appliance must be installed in the exact locations and positions described in the steps below. Failure to install the logs correctly will result in an impaired flame effect. .

All logs and fuel elements are marked with an individual code. The fuel bed is also marked with the same corresponding code and accompanying stencilled outline. Most of the logs feature a small peg on the underside that will slot into a corresponding hole on the fuel bed.



Six of the logs feature internal LED illumination. These need to be plugged into ports located on the fuel bed. Take care not to damage the connector pins at this point as it may result in malfunction.

Follow the sequence steps detailed below. For further assistance, scan the QR code to access a video guide.

Step 1. Install the central back panel up-light. Use the thumbscrews provided to secure the light, and ensure the cables are plugged into the connectors on the fuel bed.

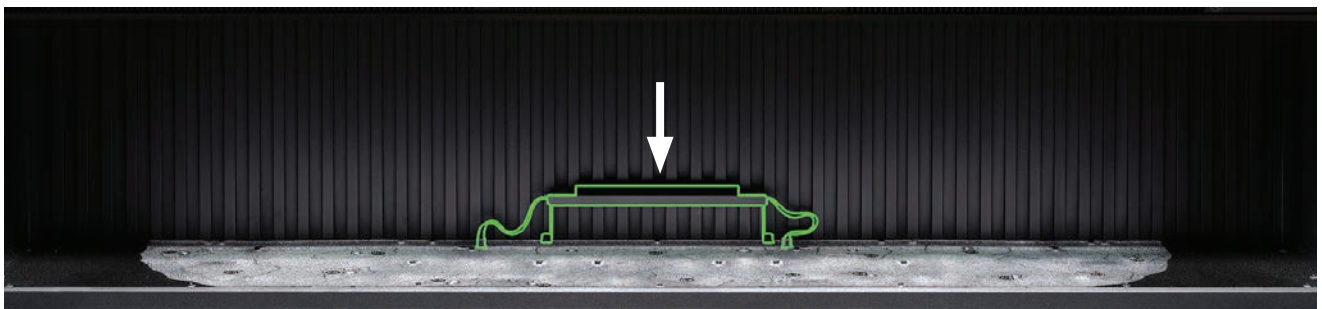

Step 2. Install the left and right back panel up-lights. Use the thumbscrews provided to secure the lights, and ensure the cables are plugged into the connectors on the fuel bed.



Step 3. Position log AI-22 onto the corresponding outline on the fuel bed, locating the peg on the underside of the log into the hole in the fuel bed.

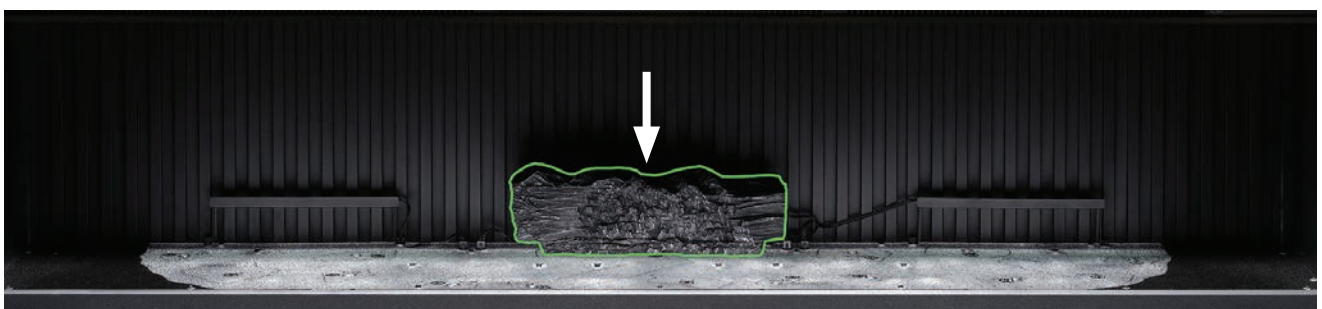

Step 4. Position log AI-20 onto the corresponding outline on the fuel bed, locating the peg on the underside of the log into the hole in the fuel bed.



Step 5. Position log AI-17 onto the corresponding outline on the fuel bed, locating the peg on the underside of the log into the hole in the fuel bed.



Step 6. Position log AI-18 onto the corresponding outline on the fuel bed, locating the peg on the underside of the log into the hole in the fuel bed.



Step 7. Position log AI-21 onto the corresponding outline on the fuel bed, locating the peg on the underside of the log into the hole in the fuel bed, and plug the cable into the connector on the fuel bed.



Step 8. Position log AI-23 onto the corresponding outline on the fuel bed, locating the peg on the underside of the log into the hole in the fuel bed, and plug the cable into the connector on the fuel bed.



Step 9. Position log AA-16 onto the corresponding outline on the fuel bed.



Step 10. Position log AI-6 onto the corresponding outline on the fuel bed, locating the peg on the underside of the log into the hole in the fuel bed, and plug the cable into the connector on the fuel bed.



Step 11. Position log AI-10 onto the corresponding outline on the fuel bed.



Step 12. Position log AI-25 onto the corresponding outline on the fuel bed, locating the peg on the underside of the log into the hole in the fuel bed, and plug the cable into the connector on the fuel bed.

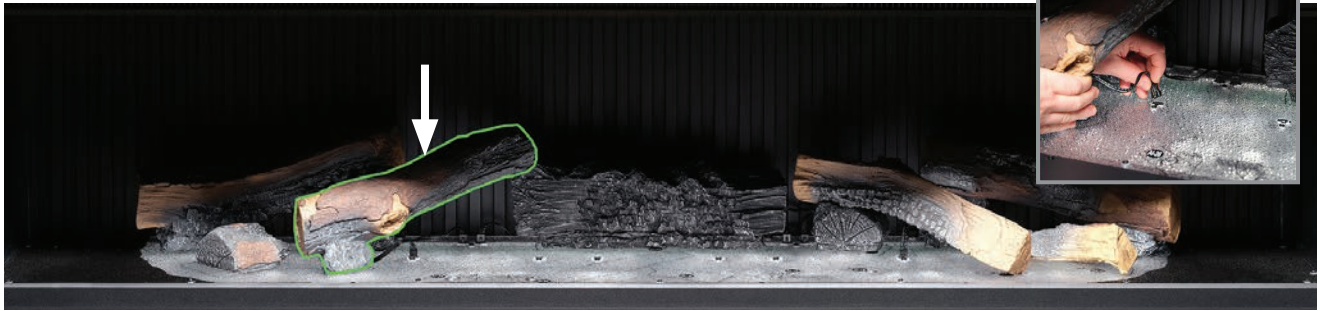

Step 13. Position log AI-18 onto the corresponding outline on the fuel bed, locating the peg on the underside of the log into the hole in the fuel bed, and plug the cable into the connector on the fuel bed.

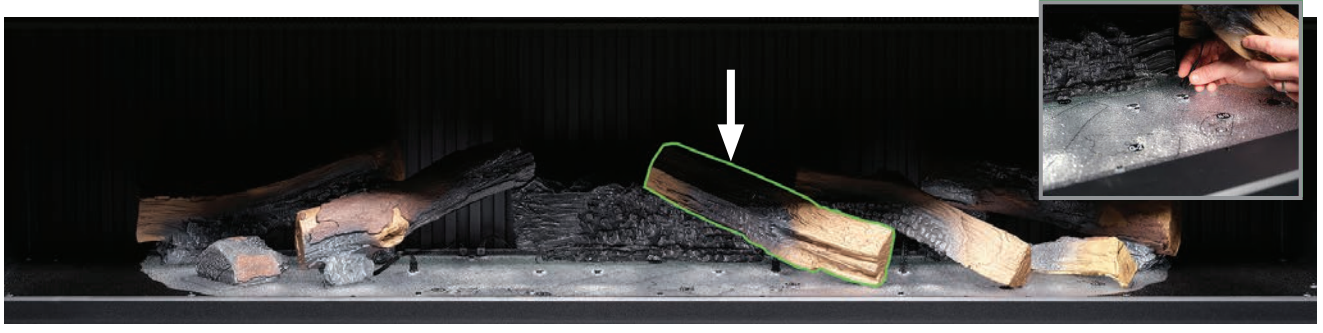

Step 14. Position log AI-26 onto the corresponding outline on the fuel bed, locating the peg on the underside of the log into the hole in the fuel bed, and plug the cable into the connector on the fuel bed.

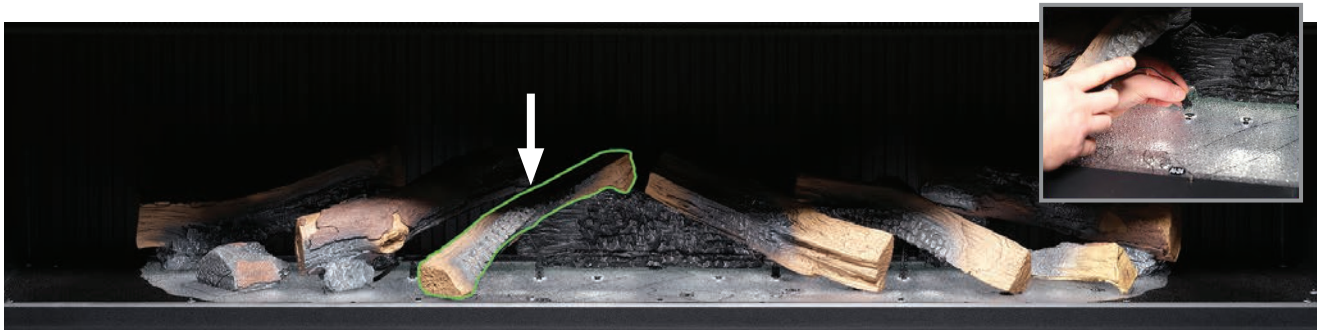

Step 15. Position log AI-24 onto the corresponding outline on the fuel bed, locating the peg on the underside of the log into the hole in the fuel bed, and plug the cable into the connector on the fuel bed.



Step 16. Position log AI-19 onto the corresponding outline on the fuel bed, locating the peg on the underside of the log into the hole in the fuel bed, and plug the cable into the connector on the fuel bed.

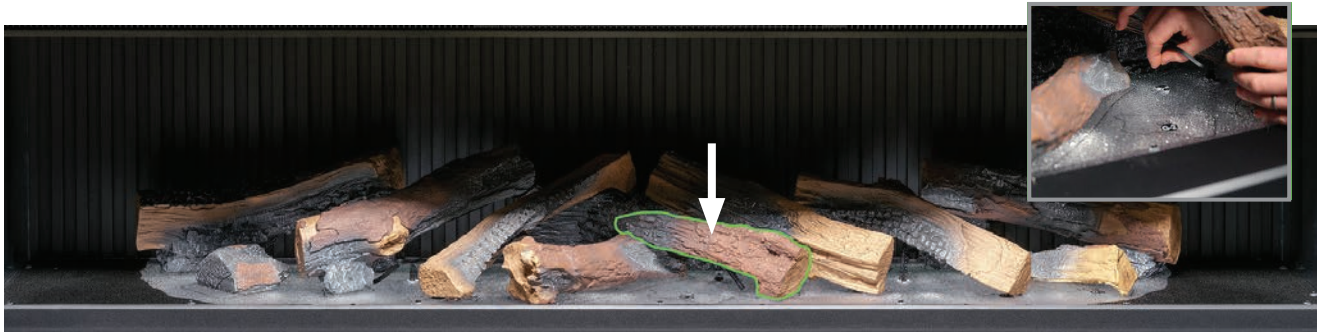

Step 17. Position log G-2 onto the corresponding outline on the fuel bed.



Step 18. Distribute the clear resin embers around the base of the logs, placing them inside the clear area of the fuel bed. Ensure good coverage, including areas underneath the raised logs.



Step 19. Distribute the black resin embers around the base of the logs, placing them inside the black area of the fuel bed. Ensure good coverage, including areas underneath the raised logs.



Step 20. **Distribute the black glass embers around the entire fuel bed, placing them over both clear and black resin embers. Do not feel that you need to use all of the black glass embers provided. At this stage it may be helpful to turn on the appliance to illuminate the fuel bed and review the coverage of embers.**



Step 21. **Take the remaining small logs and bark pieces and arrange them randomly around the fuel bed, Pressing them down into the embers. The small pieces of bark can be used to conceal any visible wires.**



Step 22. **Distribute the grey and black slate chips around the fuel bed. Finally, re-fit the flame screen ensuring the correct surface is forward and check for proper alignment of flames on the logs.**



The logs and other fuel elements provided with the appliance must be installed in the exact locations and positions described in these steps. Failure to install the logs correctly will result in an impaired flame effect.



When the appliance is turned on for the first time, the fuel bed will flash orange for a short time. This indicates that the appliance is warming up. The flashing will cease after approximately 10 seconds and the flame effect will activate.

For further assistance, scan the QR code to access a video guide showing how to successfully install the fuel bed.

Complete the setup by carefully re-fitting the front glass using the suckers provided, then re-fit the glass retaining bar following the steps detailed on page 24 in reverse.



SPECIFICATIONS

PRODUCT SPECIFICATIONS

Model	Unit	EL1000	EL1300	EL1500	EL1800
Weight Net/Gross	kg	64.6 / 84.4	82.5 / 105.3	89.2 / 115	103.2 / 133.5
Dimensions H x W x D	mm	586 x 1006 x 513	586 x 1306 x 513	586 x 1506 x 513	586 x 1806 x 513
Mains Electricity Supply	VAC / Hz	230-240 / 50	230-240 / 50	230-240 / 50	230-240 / 50
Three Pin Plug Type	Amp	10	10	15	15
Length of Power Lead	mm	1700	1700	1700	1700
Power for Flame Effect	W	45	75	75	75
Power for Ambient Light Kit	W	18	18	18	18

HEAT OUTPUT	SYMBOL	VALUE		UNIT
		EL1000 / EL1300	EL1500 / EL1800	
Nominal Heat Output	P_{nom}	2	3	kW
Minimum Heat Output	P_{min}	1	1.5	kW
Maximum Continuous Heat Output	P_{max}	2	3	kW

AUXILIARY ELECTRICITY CONSUMPTION				
At Nominal Heat Output	e_{lmax}	12.5		W
At Minimum Heat Output	e_{lmin}	12		W
In Standby Mode	e_{lSB}	3		W

TYPE OF HEAT OUTPUT / ROOM TEMPERATURE CONTROL	YES / NO
With electronic room temperature control	YES
Electronic room temperature control plus day timer	YES
Electronic room temperature control plus week timer	YES

OTHER CONTROL OPTIONS	YES / NO
Room temperature control, with open window detection	YES
With distance control option	YES
With adaptive start control	YES

ITEMS	MAIN CONTROL BOARD	WI-FI MODULE	REMOTE CONTROL
Hardware	RC01-101B01	WBR03	RC455A V2.0
Software/Logic	V02.012	/	C.0.5
Frequency	FSK 433.92MHz	2.4GHz	FSK 433.92MHz
Maximum Transmit Power	80mW	18dBmW	80mW

TECHNICAL INFORMATION

Front Aspect

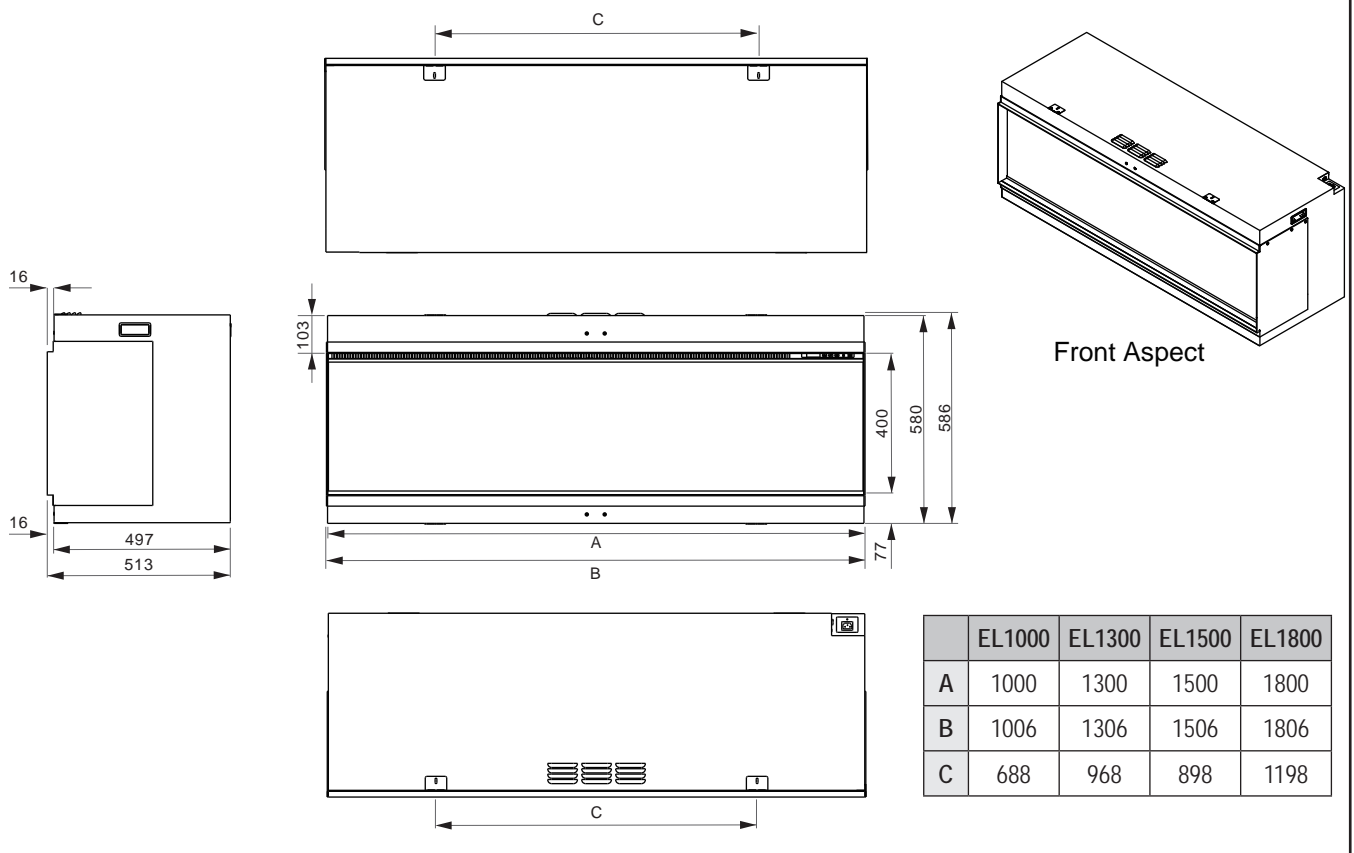

Three-sided Aspect

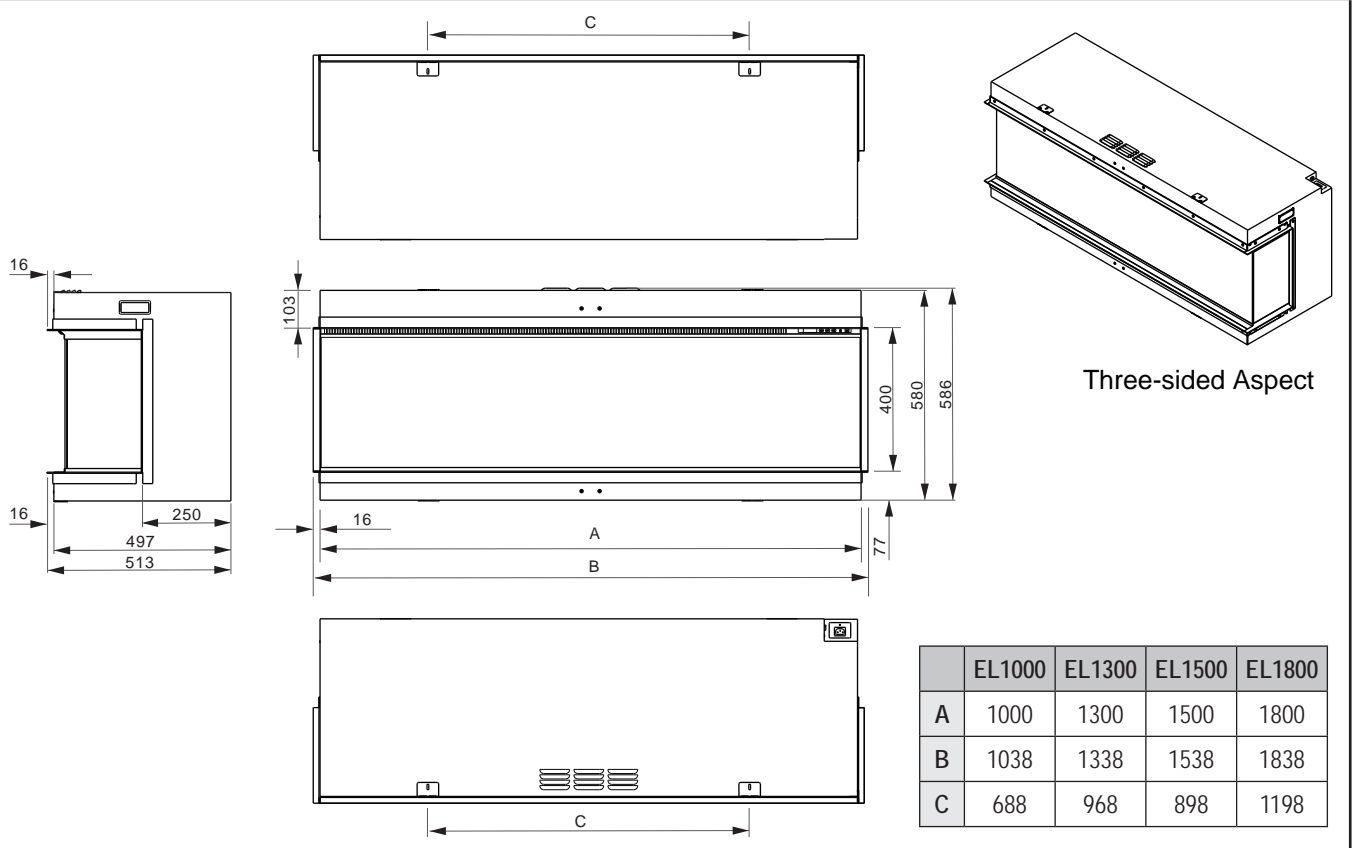

All dimensions are in cm unless otherwise specified

TERMS OF WARRANTY – AUSTRALIA

Rinnai Australia Pty. Ltd. ABN 74 005 138 769, 100 Atlantic Drive, Keysborough VIC 3173.

1 DEFINITIONS

The terms listed below shall have the following meanings:

- 1 **“Authorised Service Representative”** means an independent service contractor authorised by Rinnai or Rinnai service personnel.
- 2 **“Rinnai”** means Rinnai Australia Pty Ltd (ABN 74 005 138 769) and any related company.
- 3 **“Certificate(s) of Compliance”** means certificate(s) issued by licensed personnel (including plumbers, refrigeration mechanics, electricians or other relevant tradespeople) to certify that any prescribed works comply with applicable regulatory requirements.
- 4 **“Certificate(s) of Occupancy”** means certificate(s) issued by the local government authority (or similar organisation) which certifies that a home can be occupied.
- 5 **“Installation Site”** means the site at which the Product is originally installed.
- 6 **“Normal Business Hours”** means 8:30am to 5:00pm Monday to Friday, excluding public holidays.
- 7 **“Operating/Installation Instructions”** means the user manual or other documentation which provides detailed instructions on the proper operation and maintenance of the Product.
- 8 **“Other Applications”** means any Product used for purposes other than Residential & Light Commercial Applications. Other Applications may include but are not limited to factory, IT/Server room, telephone exchange, processing area (e.g. bakery, kitchen, warehouse, swimming pool, agricultural facilities such as a nursery). Any Product which has been installed, for whatever purpose, as a retrofit component to an existing system, will also be classed as being part of an “Other Application” regardless of the purpose of use of the existing system into which such product has been installed.
- 9 **“Purchaser”** means the end user of the Product, the person named as owner in the Warranty certificate, the holder of the Proof of Purchase or the holder of a property transfer document where the Product is included as part of the chattels.
- 10 **“Product”** means the equipment purchased by the Purchaser and described in Section 2 of this document.
- 11 **“Proof of Purchase”** means a Tax Invoice or Receipt in respect of the Product. In the case of new constructions, a Certificate of Occupancy or a Certificate of Compliance that details the date of installation or commissioning will suffice.
- 12 **“Qualified Installer”** means the qualified installation contractor who is responsible for performing the installation work in the manner prescribed by local and statutory regulations, including compliance with any relevant and to Rinnai specifications, including Australian Standards.
- 13 **“Residential & Light Commercial Applications”** means any Product for use in residential or light commercial applications where
 - a) the Product is solely used for the purpose of human comfort; and
 - b) the ambient temperature of the space the Product is intended to heat or cool is influenced solely or primarily by natural exterior weather conditions rather than by man-made or mechanical heat sources.

Examples of Residential & Light Commercial Applications include, homes, offices, hotels, apartments, nursing homes, hospitals, health care premises, shopping centres, and retail stores.

2 TERMS OF WARRANTY

- 2.1 Subject to the Terms of Warranty set out in this document, effective from the date of purchase by the Purchaser, the Product is warranted to be free from defects in materials & factory workmanship for the period set out in table below:

	PRODUCT GROUPS	PARTS	LABOUR
Residential and Light Commercial	Evaporative Coolers & Ducted Gas Heaters (excluding Compact Classic Series)	5 Years *Extended 4 Years Option	5 Years *Extended 4 Years Option
	Ducted Gas Heaters - Compact Classic Series	3 Years	3 Years
	Refrigerated Air conditioning Products	5 Years	5 Years
	Ducted Gas Heaters - Heat Exchangers and Burners Evaporative Coolers - Structural components only	10 Years	N/A
	Portable Air conditioning / Dehumidifier / Air Purifier	2 Years	N/A
	Electric Panel Heaters ⁽¹⁾	7 Years	N/A
	Electric Fire Heater	5 Years	5 Years
	Wi-Fi Devices	1 Year	1 Year
Other Applications	All Product Groups	2 Years	1 Year
After Market	Spare Parts	1 Year	N/A
*Extended Warranty Option	Up to 4 year extended warranty (in addition to the standard warranty period listed above) applies on selected products when you opt in to the Rinnai Service Advantage program. This program has terms and conditions, including the requirement for scheduled servicing of the product by Rinnai. To participate in the program you must register your product online at: www.rinnai.com.au/support-resources/warranty-registration/ within the first 12 months of the product being installed.		

⁽¹⁾ To make a claim under this warranty, please contact your place of purchase within the warranty period.

- 2.2 Rinnai will determine in its sole discretion, which classification the Product fits into and the corresponding Warranty that shall apply.
- 2.3 An Authorised Service Representative will repair or replace, at its option, the Product or any part of the Product that its examination shows to be defective. The repair or replacement shall be performed during Normal Business Hours by an Authorised Service Representative. Repair by persons other than an Authorised Service Representatives may void the Warranty.
- 2.4 Alternatively to clause 2.3 above, Rinnai can at its discretion elect to pay you an amount equivalent to the cost of repairing or replacing the Product.
- 2.5 If Rinnai provides you with either the replacement costs or replacement product, ownership of the original Product shall immediately transfer to Rinnai.
- 2.6 Rinnai is responsible for reasonable costs associated with legitimate warranty claims, including call-out of an Authorised Service Representative to inspect the Product. Rinnai is not responsible for:
- costs for tradespeople engaged by you that are not Rinnai Authorised Service Representatives.
 - any costs, including call out costs for a Rinnai Authorised Service Representatives, associated with a Product which is determined upon inspection not to be covered by this warranty.
- 2.7 Rinnai will reimburse any reasonable costs associated with making a legitimate warranty claim against Rinnai which are not otherwise specified above.
- 2.8 The Warranty of the Product requires that, in addition to all other conditions, the Purchaser conducts regular and/or preventative maintenance as may be specified by the Operating/Installation Instructions or otherwise directed by Rinnai and required by the level of usage and the usage environment, including the use of correct and uncontaminated refrigerants and lubricants. Refrigeration, plumbing and electrical works must be undertaken by licensed personnel.
- 2.9 Where a Product or failed component is replaced under warranty, the time remaining on the original Product warranty period will continue to apply and the replacement product or part will be subject to the original warranty period only.

3 CONDITIONS OF WARRANTY

- 3.1 The Purchaser may only obtain the benefit of the Warranty if the Purchaser:
- maintains and has the Product serviced in accordance with the instructions set out in the service section of the relevant Service or Owner's Manual;
 - complies with clause 7 "Purchaser's Responsibilities" on page 48;
 - notifies Rinnai within 30 days of a defect occurring or, in the case of a latent defect, becoming apparent, that a claim is being made under this Warranty; and
 - provides, in support of the claim made under this Warranty, a Proof of Purchase.
- 3.2 This document (and any statutory consumer guarantees) represents the only Warranty given by Rinnai in respect of the Product. No other person or organisation is authorised to offer any alternative warranty on behalf of Rinnai.
- 3.3 If the date of purchase cannot be established to Rinnai's satisfaction, the date shall be deemed to be 2 months after the date of manufacturer or the date of sale by Rinnai, whichever is the latter.
- 3.4 This warranty applies to Products which are manufactured on or after the date of publication of this warranty but before the next date of publication of this warranty.

4 EXCLUSIONS

- 4.1 This Warranty **does NOT** cover:
- damage, problems or failure resulting from improper operation and/or inadequate maintenance by the Purchaser (refer Purchaser's Responsibilities section below);
 - damage, problems or failure resulting from improper or faulty installation. The Product must be installed by a Qualified Installer in accordance with applicable regulations. Where applicable, Certificate(s) of Compliance must be obtained by the purchaser from the Qualified Installer and presented to the Authorised Service Representative;
 - damage, problems or failure caused by factors external to the Product including, but not limited to, faulty or poor external electrical wiring, incorrect or faulty power supply, voltage fluctuations, over voltage transients or electromagnetic interference, inadequate or faulty gas, drainage services, or water services, including water pressure, and non-potable water;
 - damage, problems or failure caused by acts of God, fire, wind, lightning, flood, storm, hail storm fallout, vandalism, earthquake, war, civil insurrection, misuse, abuse, negligence, accident, pests, animals, pets, vermin, insects, spiders/bugs or entry of foreign objects or matter into the Product such as dirt, debris, soot or moisture;
 - damage, problems or failure caused by environmental conditions including, but not limited to, excessive moisture, salt or other corrosive substances or atmospheric conditions;
 - Product which has been installed in a portable or mobile building, structure or application including, but not limited to, a caravan, boat or trailer;
 - Product which has been re-installed at a location other than the original site;
 - any consumable item supplied with the Product including, but not limited to, an air filter, battery, fan belt, igniter or cooler pad;
 - installation of third-party components that may be attached to the Product. These include, but are not limited to, control wiring, ducting, return air filter(s) grille, register, diffuser, zone motors, controls/thermostats, pipe work and fabricated or added components. These items remain solely the responsibility of the Qualified Installer;
 - installations where electrics/electronics may be subjected to moisture/chemicals (e.g. swimming pools or nurseries);
 - any repair, which is needed as a result of an accident, misuse, abuse or negligence;
 - Product that is utilised in an environment (indoor and outdoor) outside its specified operating range; and
 - fair wear and tear to the Product.
 - On-site labour warranty on portable (non-fixed installation) Products – In respect of such Products the Purchaser must return the Product to the supplier for repair or replacement).

5 LIMITATIONS

- 5.1 Third parties are often involved in providing advice to consumers about the climate control solutions best suited to the consumer's needs. Any advice or recommendations given by such parties, including advice about Product fitness for purpose and overall system design, sizing and application are not the responsibility of Rinnai. This includes but is not limited to the heat load calculations, airflow and system balancing.
- 5.2 This Warranty does not apply to any Product installed at an Installation Site which is outside Australia.
- 5.3 Except where inconsistent with the purchaser's statutory rights and the rights given by this Warranty, all liabilities of Rinnai for any direct, special, indirect or consequential loss or damage, any damage or expense for personal injury or any loss or destruction of property, arising directly or indirectly from the use or inability to use the Product or any of its parts and/or servicing the Product, are expressly excluded.

6 TRAVEL, TRANSPORT & ACCESS COSTS

- 6.1 The Purchaser must pay freight charges, in-transit insurance expenses and travelling costs for repairs/replacements under this Warranty, that are required to be performed 50km from the nearest Rinnai branch or Authorised Service Representative.
- 6.2 Subject to clause 6.3, Rinnai will pay freight charges, in-transit insurance expenses and travelling costs for repairs/replacements that are required to be performed less than 50km from the nearest Rinnai branch or Authorised Service Representative, subject to the following:
- a) Rinnai will arrange for such repairs/replacements and make any payment directly to the third party to provide the freight, in-transit insurance or travel services; or
 - b) if Rinnai considers appropriate, it will authorise the Purchaser in writing to pay for the relevant freight charges, in-transit insurance expenses or travelling costs and then, upon provision by the Purchaser to Rinnai of a tax invoice showing those costs have been incurred, reimburse the Purchaser for such costs which are within the terms of the authorisation. If the Purchaser pays for the relevant freight charges, in-transit insurance expenses or travelling costs without written authorisation from Rinnai, Rinnai will not reimburse the Purchaser for such costs.
- 6.3 The Purchaser must pay all costs and expenses in respect of:
- a) any service call out fee if the Product is not accessible for service
 - b) making the Product accessible for service, for example, restricted access or working at heights, or the labour cost for an additional person due to OHS requirements.
 - c) providing a safe working environment for installation, service, maintenance or repair of the Product;
 - d) any surcharge applicable in respect of supplying replacement parts outside Normal Business Hours; and
 - e) any other costs and expenses in relation to claiming the Warranty that is not covered by clause 6.2.

7 PURCHASER'S RESPONSIBILITIES

- 7.1 The Purchaser must operate and maintain the Product in accordance with the Operating Instructions and service maintenance schedule, including conducting an appropriate number of services to the unit during the Warranty period, based on usage and the usage environment including but not limited to;
- a) regularly cleaning the air filter(s) and replacing them where necessary;
 - b) replacing expired batteries or other consumables as required;
 - c) ensuring that the condensate drain is kept clean and clear of obstructions.

HOW TO MAKE A WARRANTY CLAIM:

If you wish to make a warranty claim in respect of any Portable Product, please return it to the place of purchase, or if that is not possible, contact Rinnai to enquire about alternative arrangements.

If you wish to make a warranty claim in respect of any fixed Product, please contact Rinnai on the details set out below to make arrangements for an Authorised Service Representative to inspect the product.

As per clause 2.6 of the Terms and Conditions of Warranty, purchasers are responsible for the costs of any repair and/or call out fee where, on inspection, the alleged defect is found by Rinnai's Authorised Service Representative not to be covered by this warranty or any statutory consumer guarantee applicable to the Product.

The Terms and Conditions of Warranty contain important information about your rights and obligations under this warranty. Please read them fully and carefully before making a claim.

NOTICE TO CONSUMERS UNDER AUSTRALIAN CONSUMER LAW

Our goods come with guarantees that cannot be excluded under the Australian Consumer Law. You are entitled to a replacement or refund for a major failure and compensation for any other reasonably foreseeable loss or damage. You are also entitled to have the goods repaired or replaced if the goods fail to be of acceptable quality and the failure does not amount to a major failure.

Our services come with guarantees that cannot be excluded under the Australian Consumer Law. For a major failure with the service, you are entitled to cancel your service contract with us and obtain a refund for the unused portion, or to compensation for its reduced value. You are also entitled to be compensated for any other reasonably foreseeable loss or damage. If the failure does not amount to a major failure you are entitled to have problems with the service rectified in a reasonable time and, if this is not done, to cancel your contract and obtain a refund for the unused portion of the contract.

The benefits provided by this Warranty are in addition to any other rights and remedies available to a consumer under the Australian Consumer Law and any other law which may apply to the goods and or services.

NOTES





Rinnai Australia Pty Ltd

ABN 74 005 138 769 | AU45204

100 Atlantic Drive, Keysborough, Victoria 3173
P.O. Box 460, Braeside, Victoria 3195
Tel: (03) 9271 6625

National Help Line

Tel: 1300 555 545*

Monday to Friday, 8.00 am to 5.00 pm EST.

**Cost of a local call may be higher from a mobile phone.
(National calls from public phones in Australia are free.)*

For further information visit **www.rinnai.com.au**
or email **enquiry@rinnai.com.au**

Rinnai has a Service and Spare Parts network with personnel who are fully trained and equipped to give the best service on your Rinnai appliance. If your appliance requires service, please call our National Help Line.

With our policy of continuous improvement, we reserve the right to change, or discontinue at any time, specifications or designs without notice.