

FUTURA RAPIDFIT PASSAGE SETS

Product Code: 10011 | 10021 | 10071

10081 | 10091 | 7314 | 7033 | 7036 | 7107 | 10001 | 10051

Print: Actual size on A4 paper

RapidFIT REMOVED

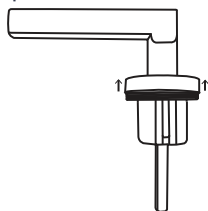

1. Unscrew the rose covers.

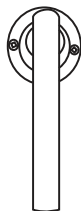

2. Remove the screw with the red screw head.



3. Remove the rapidFIT boss from the handle.

- 1 Measure the thickness and mark the centre at the desired height for the latch.

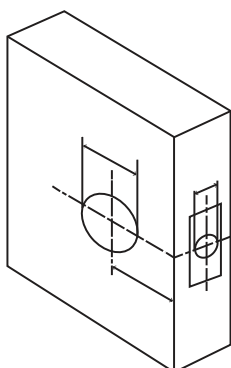

- 2 Drill a 25mm(1") diameter hole through the door edge to a depth of atleast 90mm. Ensure this hole is square to the door.

- 3 Mark the face of the door each side for drilling a 48mm diameter spindle hole. The centre of the spindle hole will need to be 60mm from the door edge (backset). We recommend using a 48mm hole saw. For clean cutouts, drill from both side, meeting in the middle of the door.

- 4 Insert the latch, scribe around the faceplate, remove, then chisel out the recess to enable the latch faceplate to sit flush the door edge.

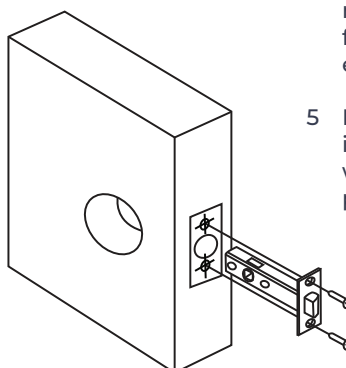

- 5 Remove any loose saw dust, insert the latch and secure it with the wood screws provided.



- 6 Insert handle 'A' in the 48mm hole with the spindle and rapidFIT attached and press against the door. Ensure the grooved side of the spindle is aligned with the grub-screws on the handle

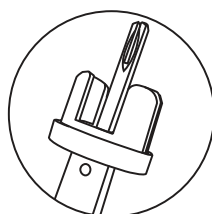
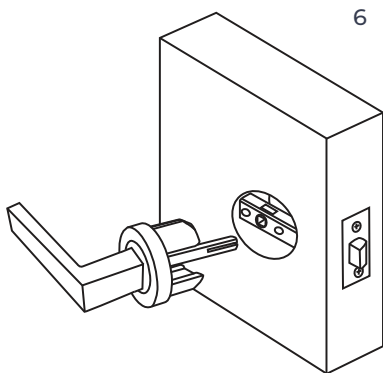

- 7 Insert handle 'B' over the spindle. Ensure the handles are straight before securing through the fixing screws.

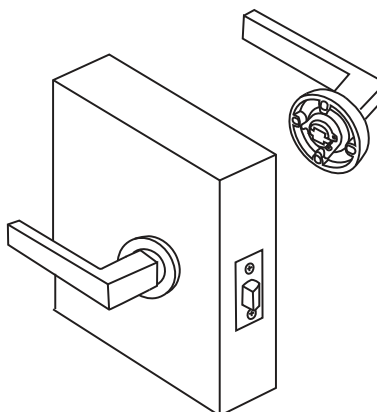

- 8 Screw the rose cover onto the handle and tighten the grub-screws on the side of the levers onto the spindle for each side of the door.

Note: The grub-screws may need a re-tighten after a bedding period. We recommend medium strength thread-lock to be used.

- 9 Close door against the frame and mark the latch position for fitting of the striker.

- 10 Router or chisel so the striker fits flush, allowing for the plastic dust-box behind the striker.

- 11 Secure the striker with the wood screws provided. Test the door and if necessary, adjust the striker and anti-rattle tab to take up any rattle.

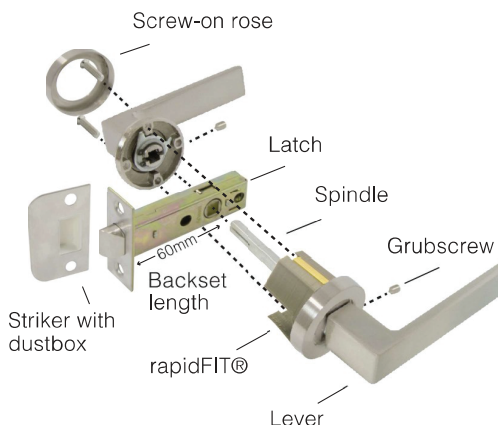
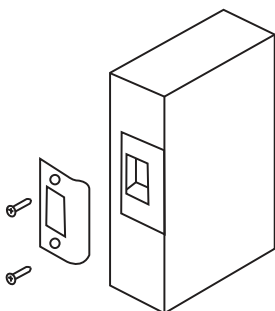

- 1 Measure the thickness and mark the centre at the desired height for the latch.
 - 2 Drill a 25mm(1") diameter hole through the door edge to a depth of atleast 90mm. Ensure this hole is square to the door.
 - 3 Mark the face of the door each side for drilling a 48mm diameter spindle hole. The centre of the spindle hole will need to be 60mm from the door edge (backset). We recommend using a 48mm hole saw. For clean cutouts, drill from both side, meeting in the middle of the door.
 - 4 Insert the latch, scribe around the faceplate, remove, then chisel out the recess to enable the latch faceplate to sit flush the door edge.
 - 5 Remove any loose saw dust, insert the latch and secure it with the wood screws provided.
 - 6 Insert handle 'A' in the 48mm hole with the spindle and rapidFIT attached and press against the door. Ensure the grooved side of the spindle is aligned with the grub-screws on the handle
 - 7 Insert handle 'B' over the spindle. Ensure the handles are straight before securing through the fixing screws.
 - 8 Screw the rose cover onto the handle and tighten the grubscrews on the side of the levers onto the spindle for each side of the door.
- Note:** The grubscrews may need a re-tighten after a bedding period. We recommend medium strength thread-lock to bed used.
- 9 Close door against the frame and mark the latch position for fitting of the striker.
 - 10 Router or chisel so the striker fits flush, allowing for the plastic dust-box behind the striker.
 - 11 Secure the striker with the wood screws provided. Test the door and if necessary, adjust the striker and anti-rattle tab to take up any rattle.