

FUTURA RAPIDFIT INTEGRATED PRIVACY SETS

Product Code: 10012 | 10022 | 10072 | 10082
10092 | 7090 | 7191 | 7192 | 7196 | 10002 | 10052

Print: Actual size on A4 paper

RapidFIT REMOVED

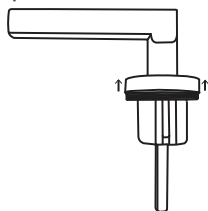

1. Unscrew the rose covers.

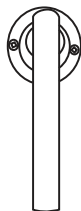

2. Remove the screw with the red screw head.



3. Remove the rapidFIT boss from the handle.

- 1 Measure the thickness and mark the centre at the desired height for the latch.

- 2 Drill a 25mm(1") diameter hole through the door edge to a depth of atleast 90mm. Ensure this hole is square to the door.

- 3 Mark the face of the door each side for drilling a 48mm diameter hole. The center of the 48mm hole will need to be 60mm from the door edge (backset). We recommend using a 48mm hole saw. For clean cutouts, drill from both sides, meeting in the middle of the door.

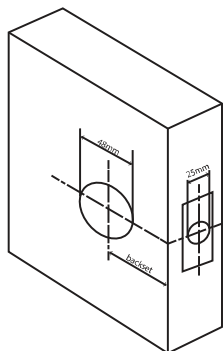

- 4 To change the handing of the latch, remove the outer faceplate, pull and rotate the latch tongue 180 degrees.

- 5 Insert the latch, scribe around the faceplate, remove, then chisel the recess to enable the latch faceplate to sit flush with the door edge.

- 6 Remove any loose saw dust and insert the latch, attach the faceplate and secure with the wood screws provided.

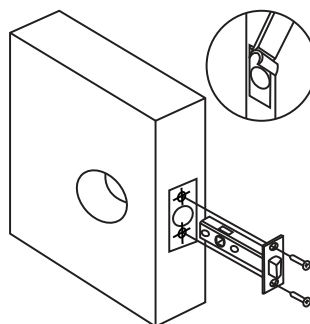

- 7 Remove the o-ring from the spindle, insert the spindle into the latch so an even amount protrudes on each side of the door and slide the o-ring back onto the spindle.

- 8 Insert handle 'A' with rapidFIT attached onto the spindle in the 48mm hole and press against the door.

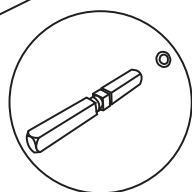
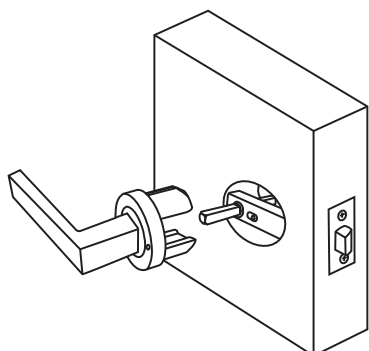

- 9 Insert handle 'B' over the spindle. Ensure the handles are straight before securing through the fixing screws.

- 10 Press the rose covers onto the handles and ensure the integrated privacy pin holes are lined up. Tighten the grub screws on the side of the levers onto the spindle for each side of the door. Tighten the grub screws on the side of the rose covers onto the roses.

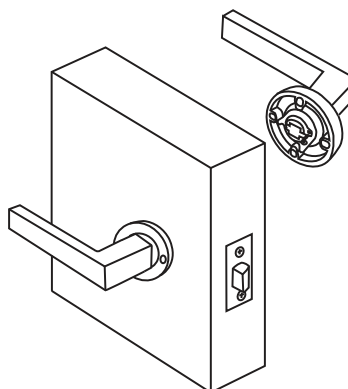

Note: The grub screws may need a re-tighten after a bedding period. We recommend medium strength thread-lock to be used.

- 11 Close door against the frame and mark the latch position for fitting of the striker.

- 12 Router or chisel so the striker fits flush, allowing for the plastic dust-box behind the striker.

- 13 Secure the striker with the wood screws provided.

- 14 Adjust the antirattle tab on the inside of the striker if necessary to ensure a firm close of the door.

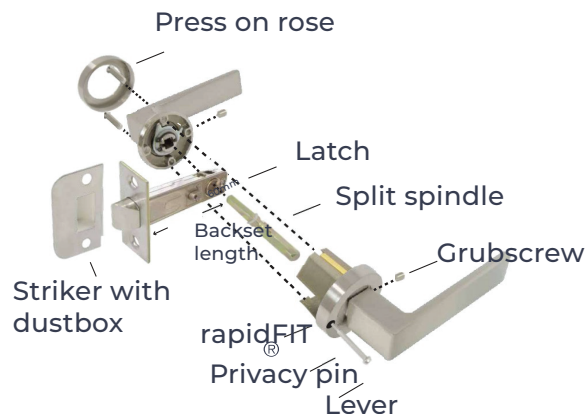
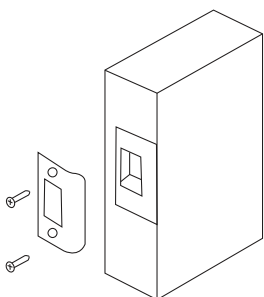

- 1 Measure the thickness and mark the centre at the desired height for the latch.
- 2 Drill a 25mm(1") diameter hole through the door edge to a depth of atleast 90mm. Ensure this hole is square to the door.
- 3 Mark the face of the door each side for drilling a 48mm diameter hole. The center of the 48mm hole will need to be 60mm from the door edge (backset). We recommend using a 48mm hole saw. For clean cutouts, drill from both sides, meeting in the middle of the door.
- 4 To change the handing of the latch, remove the outer faceplate, pull and rotate the latch tongue 180 degrees.
- 5 Insert the latch, scribe around the faceplate, remove, then chisel of the recess to enable the latch faceplate to sit flush with the door edge.
- 6 Remove any loose saw dust and insert the latch, attach the faceplate and secure with the wood screws provided.

7 Remove the o-ring from the spindle, insert the spindle into the latch so an even amount protrudes on each side of the door and slide the o-ring back onto the spindle.

8 Insert handle 'A' with rapid-FIT attached onto the spindle in the 48mm hole and press against the door.

9 Insert handle 'B' over the spindle. Ensure the handles are straight before securing through the fixing screws.

10 Press the rose covers onto the handles and ensure the integrated privacy pin holes are lined up. Tighten the grubscrews on the side of the levers onto the spindle for each side of the door. Tighten the grubscrews on the side of the rose covers onto the roses.

Note: The grubscrews may need a re-tighten after a bedding period. We recommend medium strength thread-lock to be used.

- 11 Close door against the frame and mark the latch position for fitting of the striker.
- 12 Router or chisel so the striker fits flush, allowing for the plastic dust-box behind the striker.
- 13 Secure the striker with the wood screws provided.
- 14 Adjust the antirattle tab on the inside of the striker if necessary to ensure a firm close of the door.

