

FUTURA RAPIDFIT LEVER SETS

Print: Actual size on A4 paper

Product Code: 10010 | 10020 | 10070
10080 | 10090 | 7015 | 7019 | 7106 | 7313 | 10000 | 10050

Futura Lever Sets are typically used on double doors without a latch. If used with a mortice lock refer to mortice lock instructions

- 1 Establish the height and position for the handle on the door.

- 2 Mark the face of the door each side for drilling a 25mm diameter spindle hole. Match the backset measurement of the passage doors throughout your home. Mark and drill two 6mm screw holes at 21mm above and below the center of the spindle hole. For clean cut-outs, drill from both sides, meeting in the middle of the door.

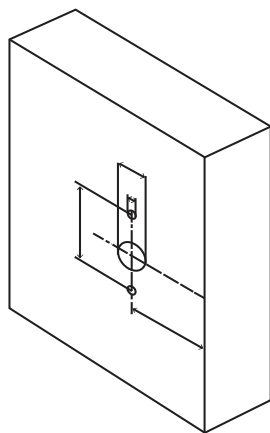

- 3 Unscrew the rose covers from the levers and unscrew the bolts from the threaded sleeves.

- 4 Insert the spindle into the handle. Ensure the grooved side of the spindle will align with the grub screws on the handles.

- 5 Insert the threaded sleeves into the oval holes in the back of the rose at two vertical positions. Screw the short bolts from the top of the rose through into the threaded sleeves.

- 6 Insert the handle into the hole and press against the door.

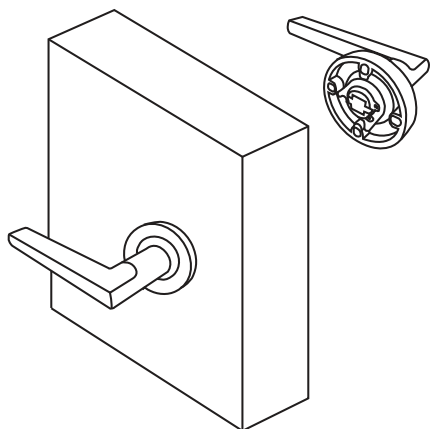
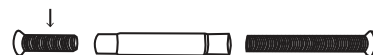
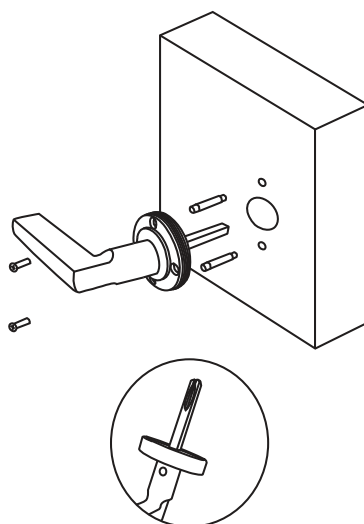

- 7 Insert the handle on the opposite side of the door over the spindle and tighten the long bolts through the rose into the threaded sleeves.

- 8 Screw the rose covers onto the handles and tighten the grub screws on the side of the levers onto the spindle for each side of the door.

Note: The grub screws may need a re-tighten after a bedding in period. We recommend medium strength thread lock to be used.